



# ART COOL PREMIER WALL MOUNTED ENGINEERING MANUAL

Art Cool Premier Wall Mounted  
3/4 and 1 Ton



# **PROPRIETARY DATA NOTICE**

**This document, as well as all reports, illustrations, data, information, and other materials is the property of LG Electronics U.S.A., Inc., and are disclosed by LG Electronics U.S.A., Inc., only in confidence.**

**This document is for design purposes only.**

DFS-EM-AG-001-US\_013M12

For continual product development, LG Electronics U.S.A., Inc., reserves the right to change specifications without notice.

©LG Electronics U.S.A., Inc.

## About LG Electronics, Inc.

LG Electronics, Inc. is a global leader and technology innovator in consumer electronics, mobile communications, and home appliances, employing more than 213,000 people in more than 60 countries worldwide. With \$136 billion (USD) revenue in 2011, LG Electronics, Inc. is ranked among Fortune 500's list of largest companies. LG Electronics, Inc. comprises five business units—Home Entertainment, Mobile Communications, Air Conditioning, Business Solutions, and Home Appliance. LG is one of the world's leading producers of flat panel televisions, audio and video products, mobile handsets, air conditioners, and washing machines. LG's commercial air conditioning business unit was established in 1968 and has built its lineup of residential and commercial products to include VRF, Flex-Multi, duct-free split systems, packaged terminal air conditioners (PTACs), and room air conditioners. In 2011, the air conditioning and energy solutions business unit grew to include LED lighting and solar products. For more information, visit [www.lg.com](http://www.lg.com).

## Duct-Free Split (DFS) Systems

LG HVAC systems offer a range of solutions that are cost efficient, quiet and attractive. Duct-Free Split (DFS) systems are “split” into indoor and outdoor units, and provide a smart alternative to both central HVAC and window-mounted air conditioners. These inverter heat pump systems are available in a variety of configurations to suit

different cooling and heating situations. Installation by a qualified HVAC contractor is safe and easy – little to no duct work or sheet metal is required.

## Inverter Systems

LG Single Zone Inverter Wall Mount air-source systems offer the opportunity to minimize ductwork in the same configuration. The system offers zoning without the need for zone damper systems. The LG Single Zone Inverter Wall Mount system's advanced controls provide exceptional building dehumidification and temperature control, and can rapidly adapt system operating parameters to the ever changing building load. The LG Single Zone Inverter Wall Mount system is easy to design, install, and maintain. The modular design allows occupants to control their environmental condition, providing individualized control of the set-point temperature and allowing occupants to condition only the occupied zones.

## Quality Commitment



LG is committed to the success of DFS projects. We provide industry leading technical support during installation and commissioning. LG offers a variety of classes designed for installers and servicers to ensure that every DFS system installation is completed successfully. Classes are conducted at LG's training centers and in field locations at various times throughout the year and upon special request.



# TABLE OF CONTENTS

INTRODUCTION .....	5	APPLICATION GUIDELINES .....	27
Architectural Appeal.....	6	Equipment Selection Procedure .....	28
PRODUCT DATA .....	7	Building Ventilation Design Guide.....	29
Product Features and Benefits .....	8	Placement Considerations .....	31
Unit Nomenclature.....	9	Single Zone Art Cool Premier.....	31
General Data .....	10	Outdoor Installation .....	32
Art Cool Premier Pairing Table .....	10	REFRIGERANT PIPING DESIGN &	
Art Cool Premier Specifications.....	11	LAYOUT BEST PRACTICES.....	35
General and Electrical Data .....	12	Refrigerant Piping Design .....	36
Outdoor Unit Dimensions .....	13	Design Guideline Summary.....	36
Indoor Unit Dimensions .....	14	Selecting Field-Supplied Copper Tubing .....	37
Acoustic Data.....	15	Installation & Layout Best Practices .....	38-42
Refrigerant Flow Diagram.....	16	Refrigerant Piping System Layout.....	38
Wiring Diagram .....	17-18	Piping Connection .....	41
Accessories .....	19-22	Electrical Connections.....	43
PERFORMANCE DATA.....	24	Mechanical Specifications.....	44
Cooling Capacity .....	24	Acronyms .....	45
Heating Capacity .....	25		

# TABLE OF SYMBOLS

 <b>WARNING</b>	<i>This symbol indicates a potentially hazardous situation which, if not avoided, may result in death or serious injury.</i>
<b>Note</b>	<i>This symbol indicates additional helpful information such as an explanation, a comment, or a clarification about the subject.</i>
	<i>This symbol indicates a recommendation or tip. Recommendations instruct the user to apply the suggested practice to ensure the best operating results in order to achieve the maximum benefit of the product. Tips contain practical information that may help the user solve a problem or describe actions that may save time.</i>

# INTRODUCTION

[“Architectural Appeal” on page 6](#)

# ARCHITECTURAL APPEAL

## Convergence of Technological Innovation with Flexibility and Style

### Benefits of Single Zone Art Cool Premier Wall Mount System

- Inverter technology
- Available in 9,000 and 12,000 Btu/h capacities
- All-season use - heat pump models for both cooling and heating capabilities
- Operating ranges for Outdoor units of 14°F (DB) to 118°F for cooling; -13°F to 75°F (WB) for heating
- Operating ranges for Indoor Units of 64°F to 90°F for cooling; 60°F to 86°F for heating
- Quiet operation inside and outside
- Duct Free Split system



### Single Zone Inverter Wall Mount

The Single Zone Art Cool Premier Wall Mount Duct Free Split (DFS) System is among the industry's best air-conditioning units. Choosing an LG Single Zone Wall Mount product provides a system designer an edge to engineer a system with individual control, and design flexibility with advanced controls. The Art Cool Premier Outdoor and Indoor units are available in a nominal capacity range of 3/4 to 1 ton. These are best suited for applications with zones that require heating or cooling, such as residential, and small business office buildings.

Single Zone Wall Mount Outdoor and Indoor units are available in 208–230V/60Hz/1Ph.

### Adaptable and Flexible

The Single Zone Wall Mount DFS System allows cooling or heating for the entire residence or just a single room without the need for evasive ductwork. There is no tearing down of walls or altering the home's appearance.

Long refrigerant piping lengths allow for extra design flexibility in indoor unit installation.

These units may be used for a number of residential or commercial environments such as:

- Older homes
- New home construction
- Office buildings
- Restaurants
- Hospitals / Medical facilities
- Schools
- Nursing homes
- Retail establishments
- House of worship



### Inverter Technology

Inverter variable-speed DFS Systems are measurably quieter and consume less energy than conventional air conditioners. The Inverter compressor ramps up or down to match the required room capacity and maintain the comfort level. When the selected temperature is reached, the inverter compressor operates at low speed to maintain that comfort level, thereby using less energy.

# PRODUCT DATA

**“Product Features and Benefits” on page 8**

**“Unit Nomenclature” on page 9**

**“General Data” on page 10**

**“Electrical Data” on page 12**

**“Outdoor Unit Dimensions” on page 13**

**“Indoor Unit Dimensions” on page 14**

**“Acoustic Data” on page 15**

**“Refrigerant Flow Diagram” on page 16**

**“Wiring Diagram” on page 17**

**“Accessories” on page 19**

# PRODUCT FEATURES AND BENEFITS

## Single Zone Art Cool Premier Wall Mount

Single Zone Art Cool Premier Wall Mount units are equipped with inverter components that offer superior load matching and long piping installation. The product works for optimizing power consumption in residential and small office buildings. Utilizing multiple indoor wall mount units each with custom temperature controls allow for precise temperature settings in each zone of the building. Art Cool Premier allows flexibility in interior design and complements any decor.

## Low Sound Levels

When outdoor units operate fully loaded, they have one of the quietest sound levels in the industry. Sound is almost undetectable during off-peak operation. To promote a quiet, comfortable environment, the LG Single Zone Art Cool Premier indoor units operate at sound levels as low as 25 dB(A) (17dB(A) in sleep mode) and outdoor units as low as 45 dB(A) at full load. LG customers often ask if the outdoor unit is running after commissioning is complete.

All rotating components are soft-started by the controller using digitally controlled inverters, which reduce undesirable noise caused by fans and compressors cycling on and off.

## Comfort Control at Its Best

Tight temperature control through precise load matching maximizes the time that the indoor units remove moisture.

Unlike traditional air conditioning control systems, which use thermostatic controls to maintain room temperatures, LG Single Zone Inverter controls continuously vary the indoor unit fan speed and refrigerant flow, indirectly providing lower and more consistent humidity levels in the conditioned space. The longer the indoor coil temperature is below the dew-point of the room in conjunction with air movement across the coil, the space humidity level will vary little, compared to technologies that cycle fans and compressors on and off multiple times per hour.

The outdoor unit responds by varying the compressor speed and outdoor fan motors as needed to maintain system operating

pressure. As a result, the Single Zone Art Cool Premier Wall Mount system delivers precise space temperature control.

## Inverter Driven

The twin-rotary compressor is optimized to maximize compressor efficiency, which reduces power consumption and monthly utility bills. This latest inverter technology allows the LG Single Zone Art Cool Premier Wall Mount outdoor unit to vary the compressor motor shaft speed to deliver an appropriate amount of cooling to the indoor unit. Precise refrigerant volume delivery translates into long periods with coil surface temperatures below dew point and minimizes compressor and fan component run time. Occupants remain comfortable while utility costs are reduced.

## Simplified Installation

Cooling and heating systems that use the LG Single Zone Art Cool Premier Wall Mount product simplify and reduce the mechanical and control system design time. The designer no longer has to be concerned with interconnecting chilled and condenser water piping, air-distribution duct systems, matching and selecting chillers, towers, pumps, coils, fans, air handlers, or Variable Air Volume (VAV) boxes.

## Operating Range

The Single Zone Art Cool Premier Wall Mount product has a nominal capacity range of 3/4 to 1 tons (depending on outdoor/indoor units). Operating ranges include:

## Art Cool Premier Outdoor Units

Cooling: 14°F DB to 118°F DB

Heating: -13°F WB to +75°F WB

## Compact Size

Single Zone Art Cool Premier Wall Mount units are available in 3/4 to 1 tons. The outdoor units have a footprint of (WxHxD) 30 5/16 x 21 1/2 x 11 5/16.

## Heat Transfer Efficiency

### Fin Design with GoldFin™ Coating

All Single Zone Art Cool Premier Wall Mount outdoor units are provided with large surface coils made of copper tubes with louvered aluminum fins designed to maximize unit operating efficiency over a wide range of ambient conditions.

Standard from the factory, every LG Single Zone Art Cool Premier Wall Mount outdoor coil fin surface is coated with LG's exclusive GoldFin™ anti-corrosive coating designed to prevent natural surface corrosion of the aluminum fins. This maintains heat transfer properties of the coil for an extended time.

A hydrophilic coating is applied to the outdoor unit coil fin surface over the GoldFin coating. This coating enhances the development of heavier water droplets gathering on the fin surface. As a result, the droplets roll off the fin surfaces, delaying the point when frost forms on the coil surface during heating operation. This coating also makes it possible to easily clean the outdoor unit coil using a mild soap.

## Other Features

- Inverter Variable Speed Compressor
- Jet Cool/Jet Heat
- Dehumidifying Mode
- Chaos Wind
- Auto restart
- Auto operation
- Self-cleaning indoor coil
- Smaller Footprint
- Precision Load Matching
- Follows AHRI 210/240





# UNIT NOMENCLATURE

## Single Zone Wall Mount Indoor and Outdoor Units

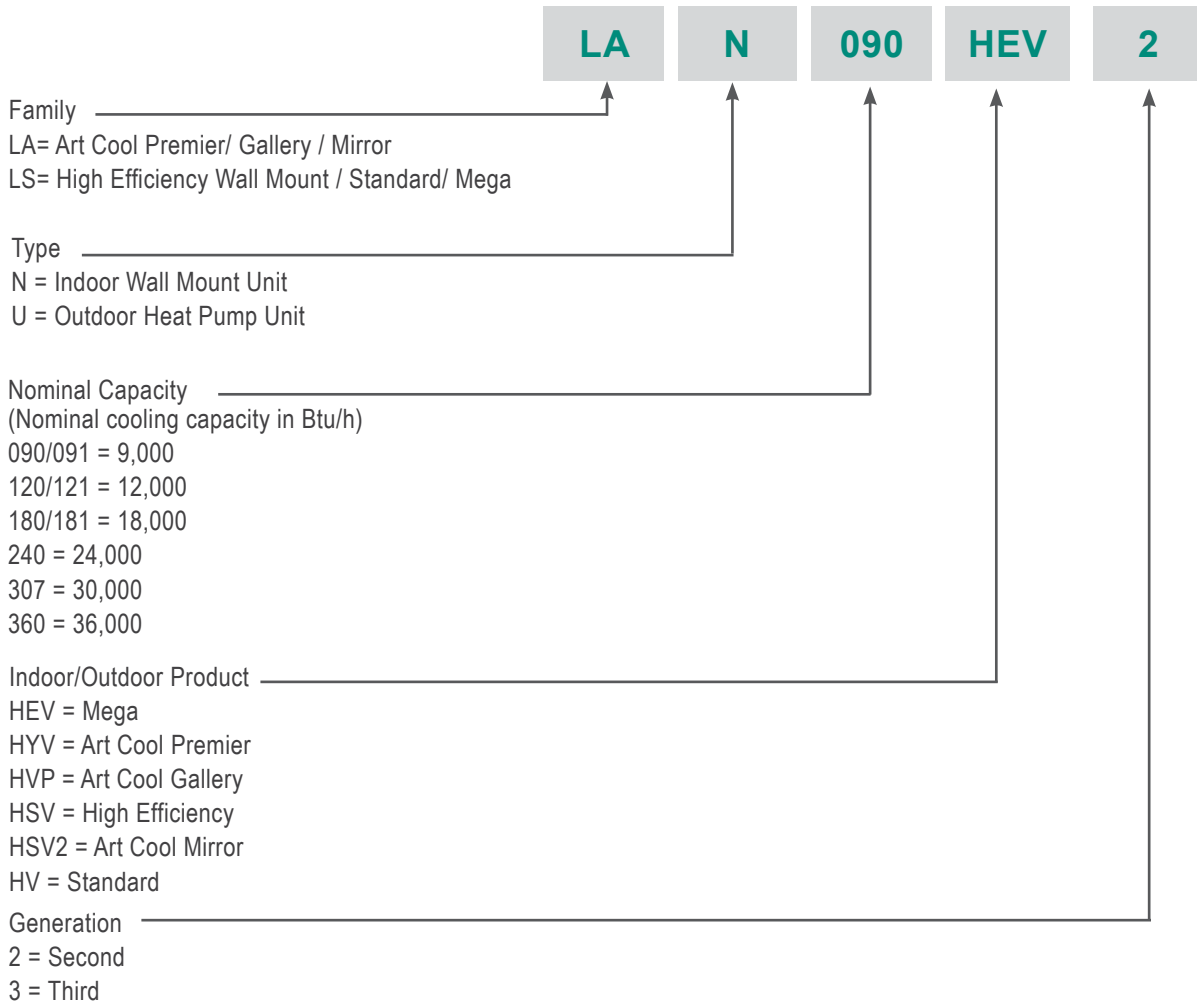



Product Data

# GENERAL DATA

## Art Cool Premier Pairing Table

The following table shows the available outdoor and indoor unit, along with the factory provided controller.

Table 1: Single Zone Art Cool Premier Pairing Table

Outdoor Unit Model/Btu/h	Indoor Unit Model/Btu/h	Controller
LAU090HYV / 9,000 LAU120HYV / 12,000 	LAN090HYV / 9,000 LAN120HYV / 12,000 	AKB73835312 

# GENERAL DATA

## Art Cool Premier Specifications

Table 2: Unit General Data

Type	Art Cool Premier	Art Cool Premier
System (Model)	LA090HYV (LAN090HYV/LAU090HYV)	LA120HYV (LAN120HYV/LAU120HYV)
Nominal Cooling Capacity (Btu/h)	9,000	12,000
Cooling Power Input <sup>1</sup> (kW)	0.56	0.85
Nominal Heating Capacity (Btu/h)	11,000	13,600
Heating Power Input <sup>1</sup> (kW)	0.70	0.86
Cooling COP	4.69	4.14
EER	16.01	14.12
SEER	27.5	25.5
HSPF	11.8	11.5
Power Supply (V / Hz / Ø)	208-230/60/1	
<i>ODU Operating Range</i>		
Cooling (°F DB)	14-118	
Heating (°F WB)	(-13)-75	
<i>IDU Operating Range</i>		
Cooling (°F WB)	64-90	
Heating (°F DB)	60-86	
<i>Indoor Temperature Setting Range</i>		
Cooling (°F)	65-86	
Heating (°F)	61-86	
<i>Unit Data</i>		
Refrigerant Type <sup>2</sup>	R410A	
Refrigerant Control	EEV	
IDU Sound Pressure <sup>3</sup> dB(A) (H/M/L/Sleep)	42/36/25/17	
ODU Sound Pressure dB(A)	45	
<i>Unit Weight (lbs)</i>		
Indoor Unit (Net/Shipping)	25/29	
Outdoor Unit (Net/Shipping)	73/78	
Power/Communication Cable <sup>4</sup> (No. x AWG)	4 x 18	
<i>Fan</i>		
Indoor Type (Qty)	Cross Flow (1)	
Outdoor Type (Qty)	Propeller (1)	
Motor/Drive	Brushless Digitally Controlled/Direct	
<i>Airflow Rate</i>		
Indoor - Max/H/M/L (CFM)	547/494/417/283	
Outdoor - Max (CFM)	1,165	

EEV: Electronic Expansion Valve IDU: Indoor Unit ODU: Outdoor Unit

Power wiring is field supplied and must comply with the applicable local and national codes.

This unit comes with a dry helium charge.

This data is rated 0 ft above sea level, with 24.6 ft of refrigerant line per indoor unit and a 0 ft level difference between outdoor and indoor units.

Cooling capacity rating obtained with air entering the indoor coil at 80°F dry bulb (DB) and 67°F wet bulb (WB); and outdoor ambient conditions of 95°F dry bulb (DB) and 75°F wet bulb (WB).

Heating capacity rating obtained with air entering the indoor unit at 70°F dry bulb (DB) and 60°F wet bulb (WB); and outdoor ambient conditions of 47°F dry bulb (DB) and 43°F wet bulb (WB).

<sup>1</sup>Power Input is rated at high speed.

<sup>2</sup>Take appropriate actions at the end of HVAC equipment life to recover, recycle, reclaim or destroy R410A refrigerant according to applicable regulations (40 CFR Part 82, Subpart F) under section 608 of CAA.

<sup>3</sup>Sound Pressure levels are tested in an anechoic chamber under ISO Standard 1996.

<sup>4</sup>All power/communication cables to be minimum 18 AWG, 4-conductor, stranded, shielded and must comply with applicable and national code.

# GENERAL AND ELECTRICAL DATA

LAU090HYV, LAU120HYV

Table 2: Unit General Data (Continued)

Type	Art Cool Premier	Art Cool Premier
System (Model)	LA090HYV (LAN090HYV/LAU090HYV)	LA120HYV (LAN120HYV/LAU120HYV)
<i>Piping</i>		
Liquid Line (in, OD)	1/4	
Vapor Line (in, OD)	3/8	
Condensation Line (OD   ID)	27/32   5/8	
Additional Refrigerant Charge (oz/ft)	0.22	
Max Pipe Length (ft) <sup>5</sup>	65.6	
Piping Length (no add'l refrigerant, ft) <sup>5</sup>	41.0	
Max Elevation Difference (ft)	32.8	

EEV: Electronic Expansion Valve IDU: Indoor Unit ODU: Outdoor Unit  
 Power wiring is field supplied and must comply with the applicable local and national codes.  
 This unit comes with a dry helium charge.  
 This data is rated 0 ft above sea level, with 24.6 ft of refrigerant line per indoor unit and a 0 ft level difference between outdoor and indoor units.

Cooling capacity rating obtained with air entering the indoor coil at 80°F dry bulb (DB) and 67°F wet bulb (WB); and outdoor ambient conditions of 95°F dry bulb (DB) and 75°F wet bulb (WB).  
 Heating capacity rating obtained with air entering the indoor unit at 70°F dry bulb (DB) and 60°F wet bulb (WB); and outdoor ambient conditions of 47°F dry bulb (DB) and 43°F wet bulb (WB).  
<sup>5</sup>Piping lengths are equivalent.

Table 3: 208-230V, 60Hz, 1-Phase Single Zone Art Cool Premier Electrical Data Table

Unit Model Nos.	Nom. Tons	Compressor Qty	Compressor(A) Cool/Heat	Fan Qty	ODU Fan(A)	MCA(A)	MOP(A)
<b>Art Cool Premier</b>							
LAU090HYV	3/4	1	8.3/8.3	1	0.40	11.2	15
LAU120HYV	1	1	8.3/8.3	1	0.40	11.2	15

For component model nos.  
 Voltage tolerance is ±10%.  
 Maximum allowable voltage unbalance is 2%.  
 MSC = Maximum Starting Current.  
 MCA = Minimum Circuit Ampacity.

Maximum Overcurrent Protection (MOP) is calculated as follows:  
 (Largest motor FLA x 2.25) + (Sum of other motor FLA) rounded down to the nearest standard fuse size.

# OUTDOOR UNIT DIMENSIONS

LAU090HYV, LAU120HYV

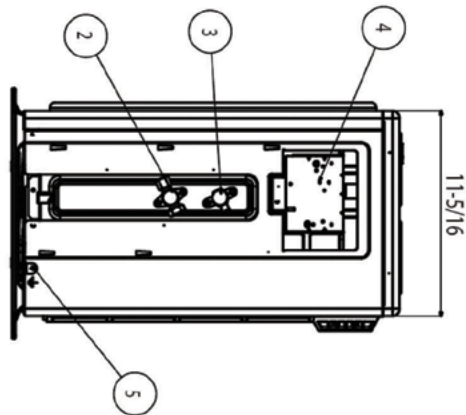
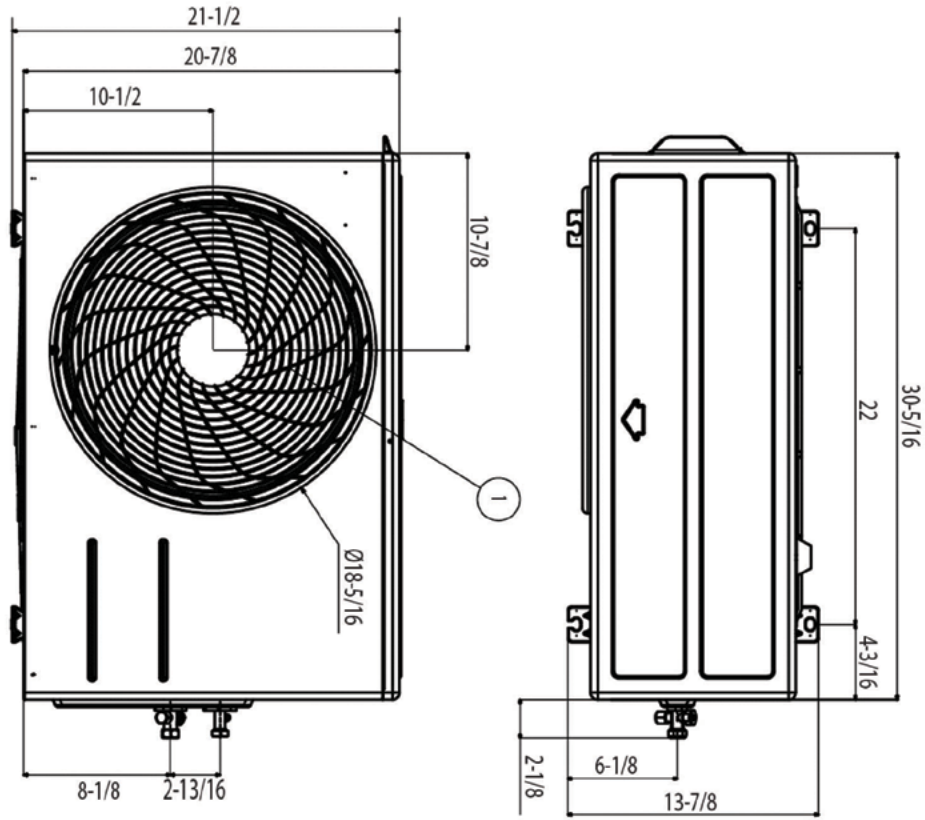

Unit: inch

Item No.	Part Name	Remarks
1	Return Air Grille	
2	Gas Pipe Connection Port	
3	Liquid Pipe Connection Port	
4	Control Box	
5	Earth Screw	

# INDOOR UNIT DIMENSIONS

LAN090HYV, LAN120HYV

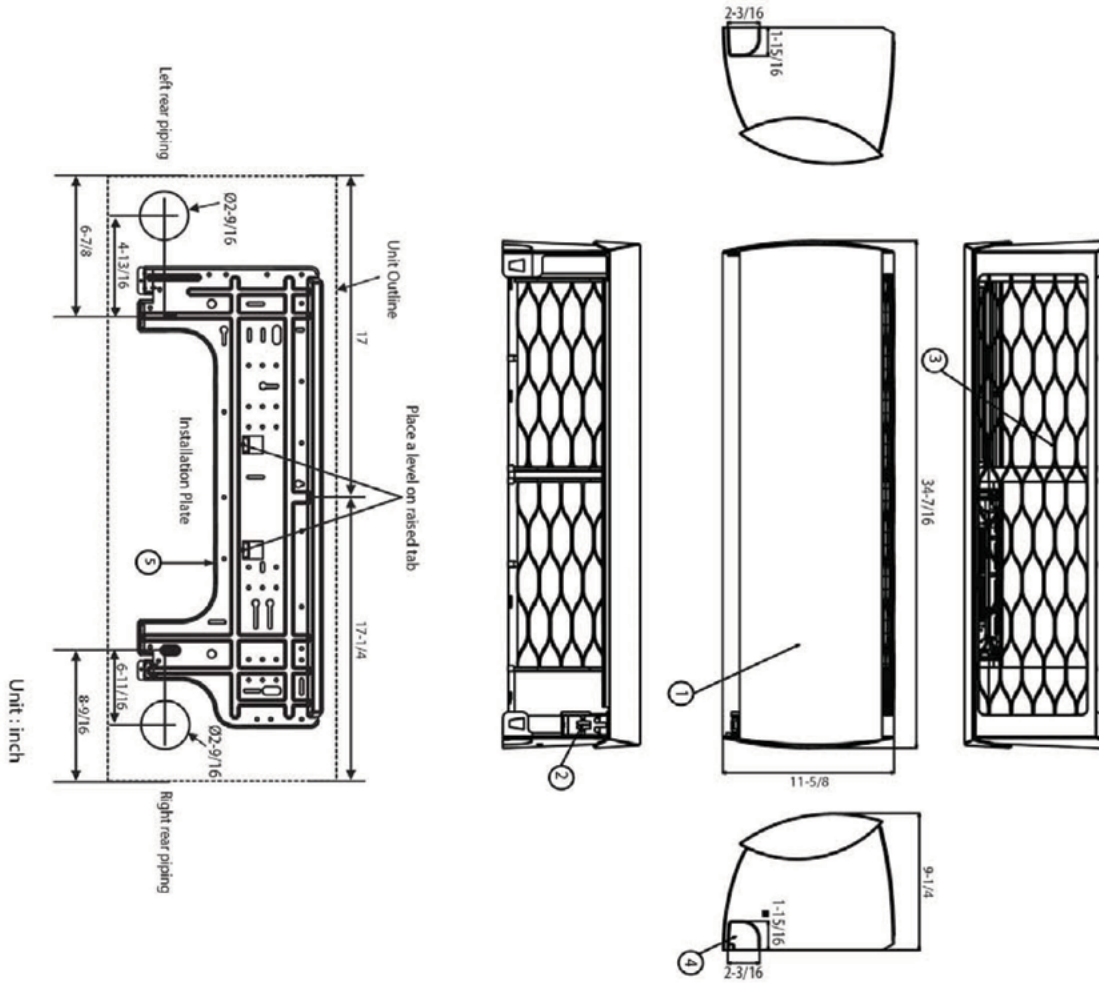

Item No.	Part Name	Remarks
1	Front Panel	
2	Display & Signal Receiver	
3	Return Air Grille	
4	Knockout Hole	For pipe and cable
5	Installation Plate	

# ACOUSTIC DATA

## Sound Pressure Levels

Figure 1: LAN090HYV, LAN120HYV

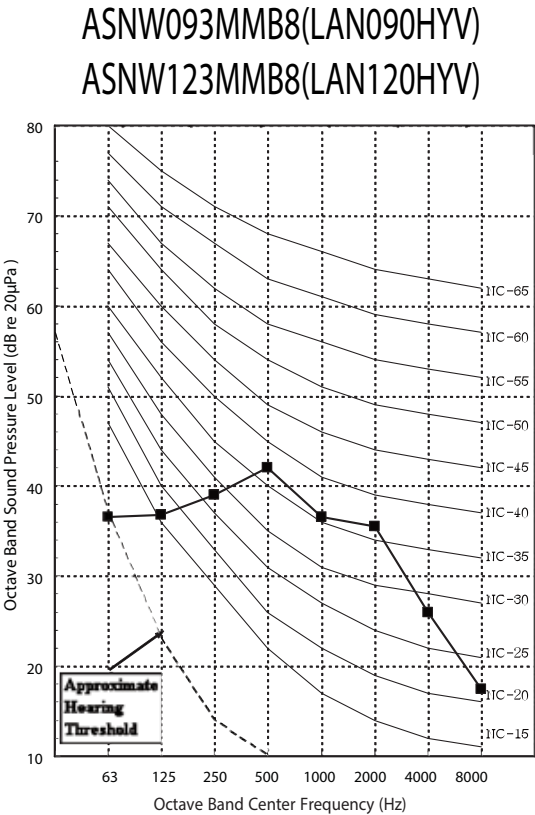
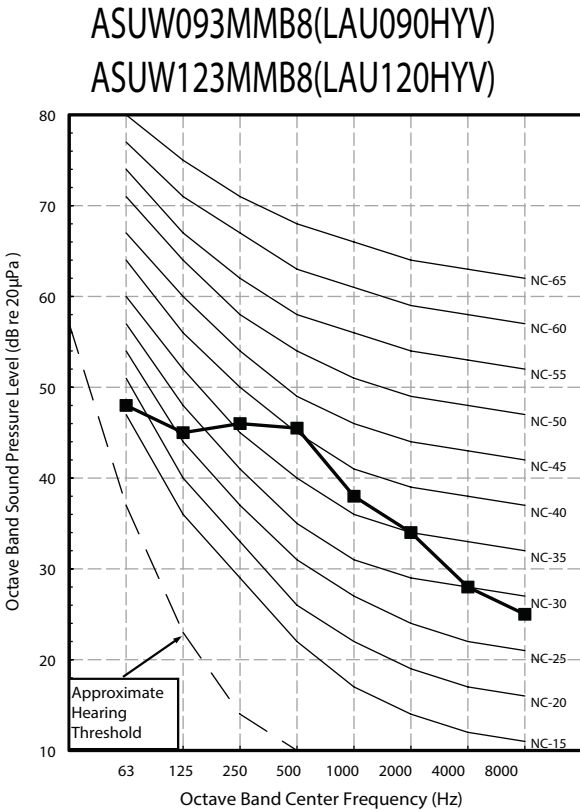

Figure 2: LAU090HYV, LAU120HYV



Product Data

# REFRIGERANT FLOW DIAGRAM

LAN090HYV, LAN120HYV

LAU090HYV, LAU120HYV

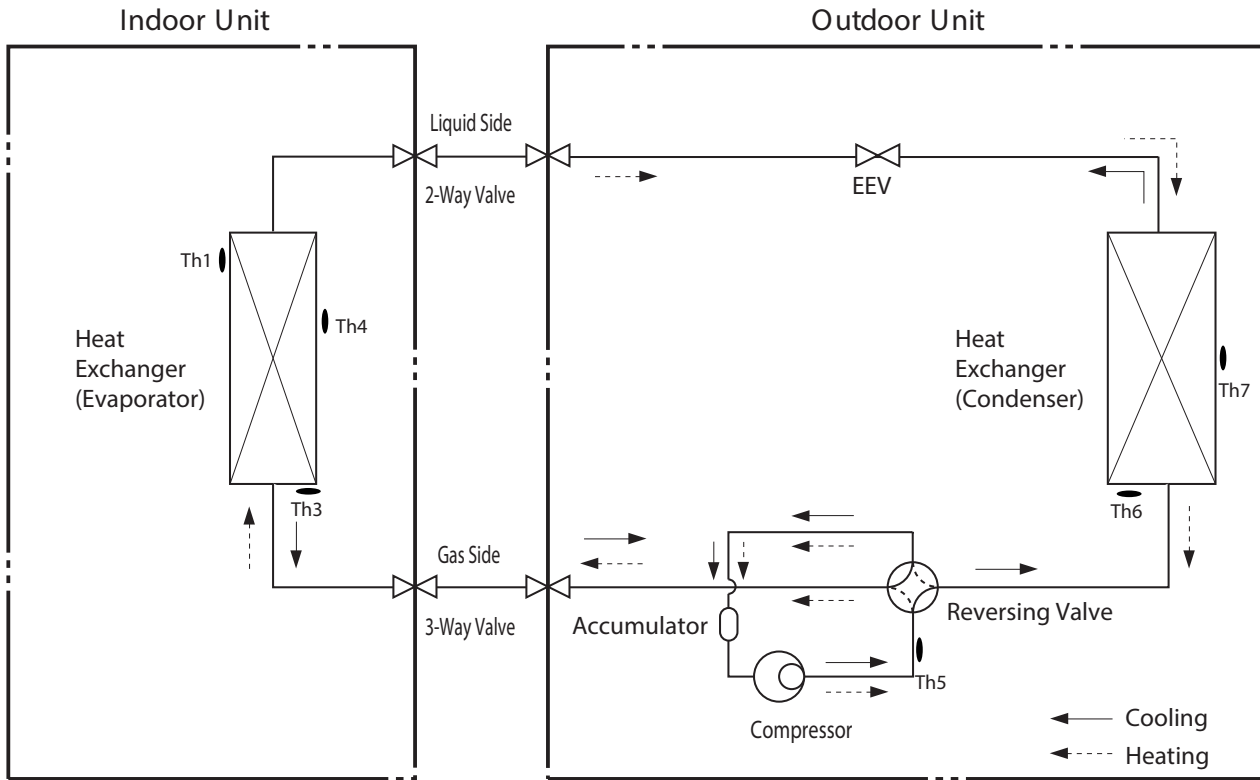

LOC.	Description	PCB Connector
Th1	Indoor air temperature thermistor	CN-TH1(Indoor)
Th3	Water level sensor (Option)	CN-TH2 (Indoor)
Th4	Evaporating middle temperature thermistor	CN-TH3 (Indoor)
Th5	Discharge pipe temperature thermistor	CN-TH2 (OUTDOOR)
Th6	Heat exchanger temperature thermistor	CN-TH1(OUTDOOR)
Th7	Outdoor air temperature thermistor	CN-TH1(OUTDOOR)

EEV : Electronic Expansion Valve



# WIRING DIAGRAM

LAN090HYV, LAN120HYV

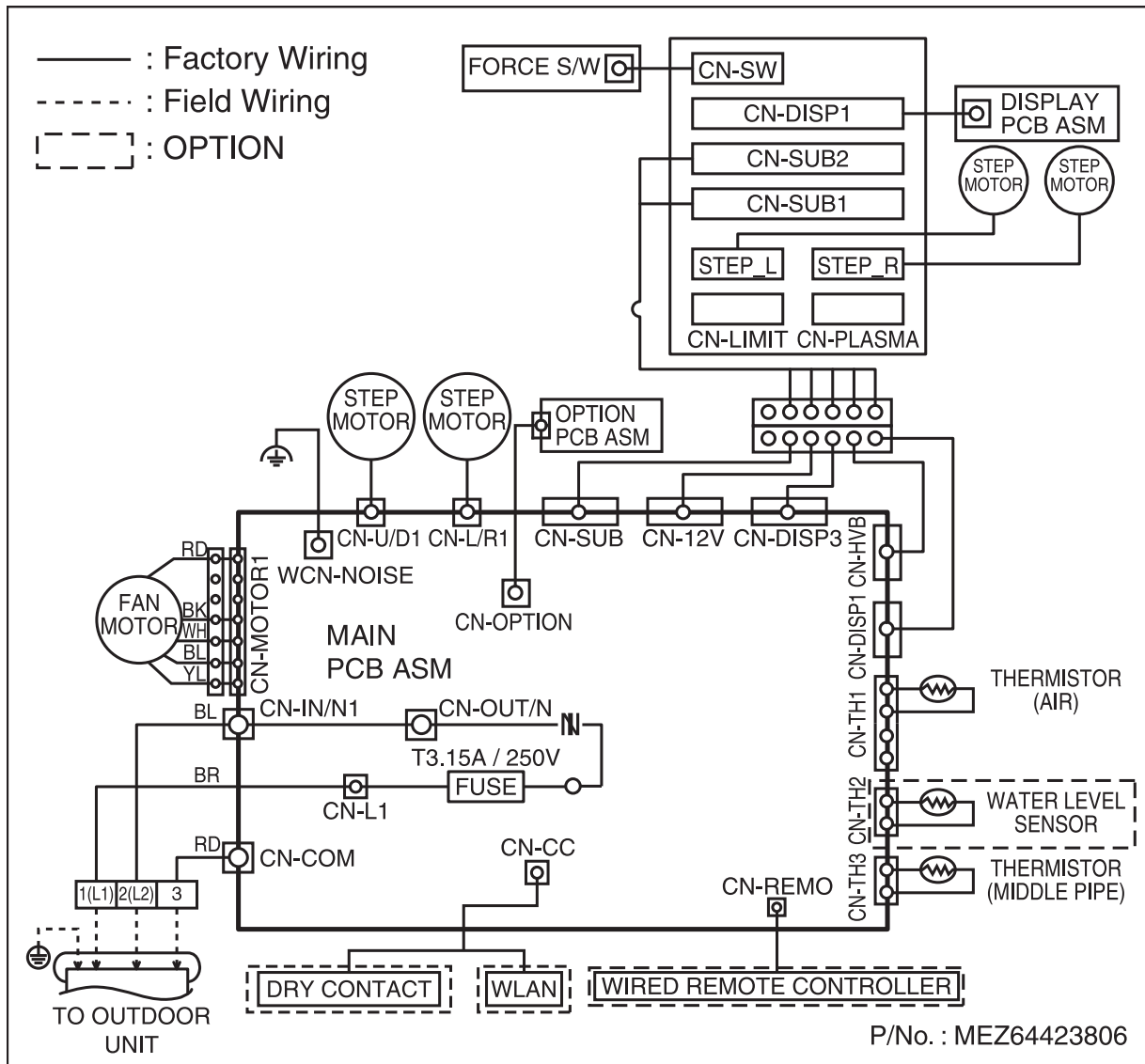

Product Data

# WIRING DIAGRAM

LAU090HYV, LAU120HYV

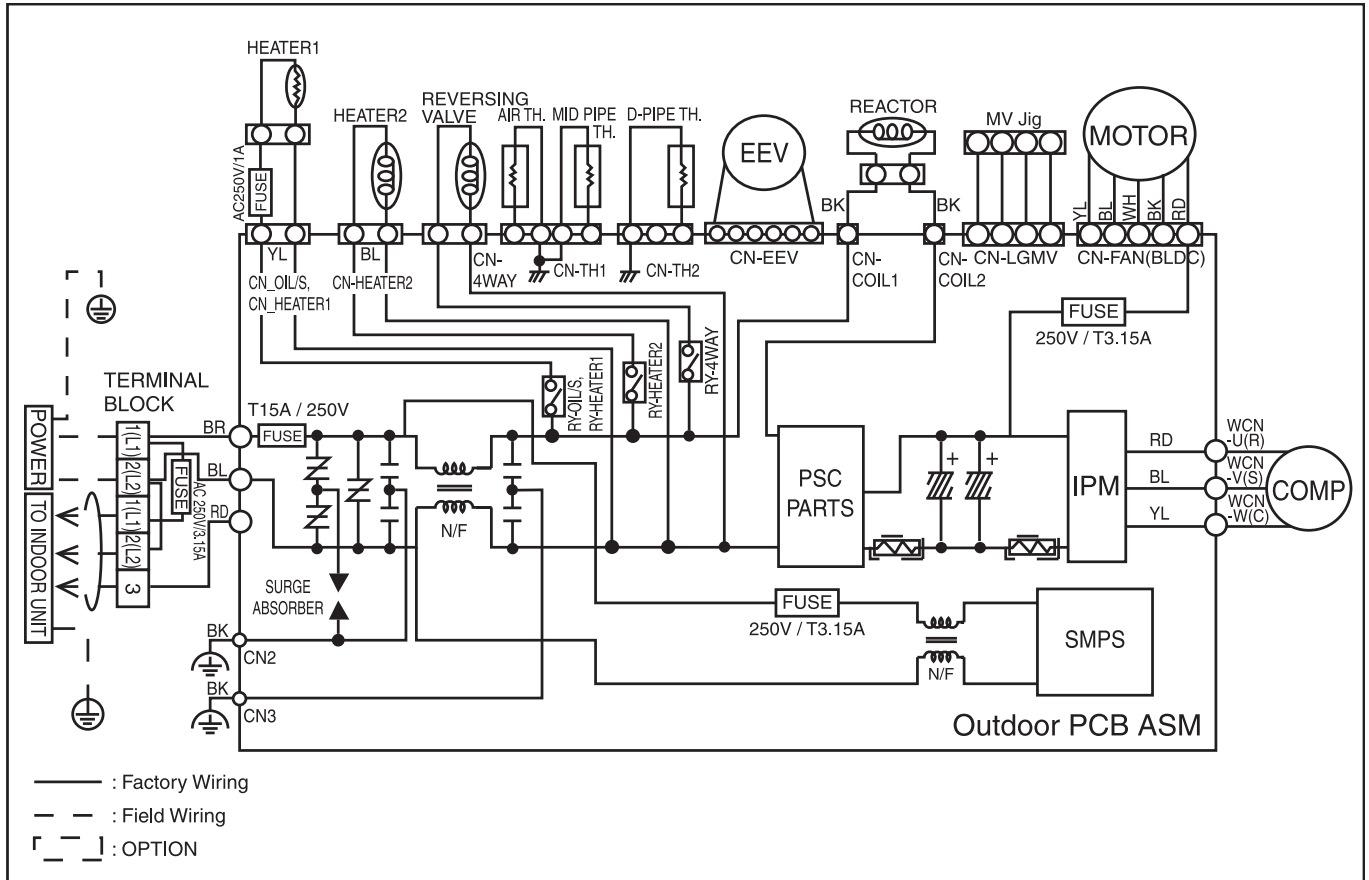





Table 4: Optional Zone Controllers

Zone Controller	Name	Model No.	Case Color	Max. Wire Length (ft.)	Description
	Simple Controller with Mode Selection	PQRCVCL0Q	Black	164	Allows control of indoor unit ON / OFF, operation mode, fan speed, and temperature setpoint.
		PQRCVCL0QW	White		
	Simple Controller without Mode Selection	PQRCHCA0Q	Black	164	Allows control of indoor unit ON / OFF, fan speed, and temperature setpoint.
		PQRCHCA0QW	White		
	LG Programmable Thermostat	PREMTB10U	White	164	Allows control of indoor unit ON / OFF, operation mode, occupied / unoccupied temperature setpoints, fan speed, and airflow direction. Programmable schedule with five events per day.

Before specifying or placing an order, refer to the V-Net Network Solutions Engineering Product Data Book, and review the detailed technical data provided to fully understand the capabilities and limitations of these devices.



Table 5: Summary Data - Zone Controller Communication Cables

Communication Cable	Name	Model No.	Max. Wire Length (ft.)	Description
	Wired Remote / Group Control Extension Cable	PZCWRC1	32	Increases the distance between a remote controller and an indoor unit, or between indoor units in a control group.

Before specifying or placing an order, refer to the V-Net Network Solutions Engineering Product Data Book, and review the detailed technical data provided to fully understand the capabilities and limitations of these devices.

# ACCESSORIES

Table 6: Summary Data—Specialty Application Devices

Specialty Application Device	Name	Model No.	Connects To	Application	Binary Signals Input / Output	Description
	Dry Contact Unit 24 VAC	PQDSB1	Indoor Unit	ON / OFF, Run Status, Error Status	1 / 2	Enables the indoor unit to be controlled and monitored by third-party controls using binary inputs and outputs.
	Dry Contact Unit for Setback	PQDSBC		ON / OFF, Mode, Controller Lock, Power Save, Run Status, Error Status	2 / 2	
	Dry Contact Unit for Thermostat	PQDSBNGCM1		ON / OFF, Thermo ON / OFF, Mode, Fan Speed, Run Status, Error Status	—	
	Digital Output (DO) Kit	PQNFP00T0	Comm. BUS	ON / OFF	0 / 1	One 25A DPST normally open relay. Used with central controller to control third-party device manually or by schedule.

Before specifying or placing an order, refer to the V-Net Network Solutions Engineering Product Data Book, and review the detailed technical data provided to fully understand the capabilities and limitations of these devices..

## LG Monitoring View (LGMV) Diagnostic Software and Cable

LGMV software allows the service technician or commissioning agent to connect a computer USB port to the outdoor unit main printed circuit board (PCB) using an accessory cable without the need for a separate interface device. The main screen for LGMV allows the user to view the following real time data on one screen:

- Actual inverter compressor speed
- Target inverter compressor speed
- Actual outdoor fan speed
- Target outdoor unit fan speed
- Actual superheat
- Inverter compressor current value
- Outdoor air temperature
- Actual high pressure/saturation temperature
- Actual low pressure/saturation temperature
- Suction temperature
- Inverter compressor discharge temperature
- Outdoor coil pipe temperature
- Liquid line pipe temperature
- Inverter compressor operation indicator light
- Four-way reversing valve operation indicator light
- Pressure graph showing actual low pressure and actual high pressure levels
- Error code display
- Operating mode indicator
- Total number of connected indoor units (for multi zone systems)
- Communication indicator lights
- Unit error code
- Indoor unit capacity
- Indoor unit operating mode
- Indoor unit fan speed
- Indoor unit room temperature
- Indoor unit inlet pipe temperature
- Indoor unit outlet pipe temperature



Additional information that can be gathered from the main screen:

1. Graph: Graphic shows the following:
  - Compressors showing actual speeds
  - EEVs
  - IDUs
  - Low and high pressures
  - Temperature sensors
  - Four-way reversing valve
  - Outdoor fans showing status and speeds
2. Setting: Converts metric values to imperial values.
3. Making Data: Recording of real time data to a separate file created to be stored on the user's computer.
4. Loading Data: Recorded data from a saved ".CSV" file can be loaded to create an LGMV session.
5. Electrical Data: The lower half of main screen is changed to show the following:
  - Inverter compressor
  - Amps
  - Volts
  - Power Hz
  - Inverter control board fan Hz

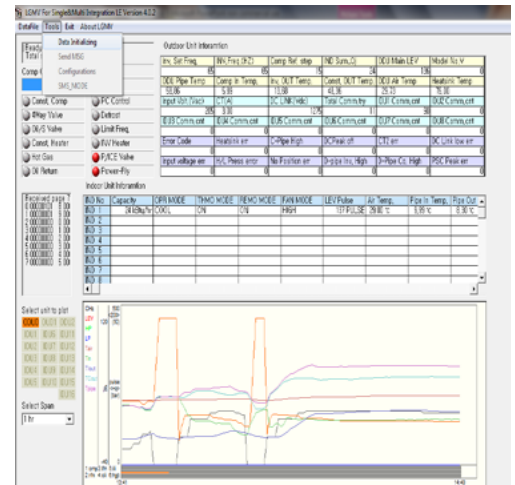

Figure 3: MV Diagnostic Screen

## LG Monitoring View (LGMV) Diagnostic Software and Cable - Continued

The software is available in a high version with all of the features listed above. The low version has all features as the high version without Target High Pressure and Target Low Pressure values shown on main screen.

In lieu of connecting to the ODU, user has the option to connect to IDU with the use of a USB to RS-485 connector kit. When connected through IDU, user will not be able to record data.

This software can be used to both commission new systems and troubleshoot existing systems. LGMV data can be recorded to a “.CSV” file and emailed to an LG representative to assist with diagnostic evaluations.

### Recommended Minimum PC Configuration:

- CPU: Pentium® IV 1.6 GHz
- Operating System: Windows® NT/2000/XP/Vista
- Main Memory: 256 MB
- Hard Disk: 600 MB when operating
- Web Browser: Internet Explorer® 5.0

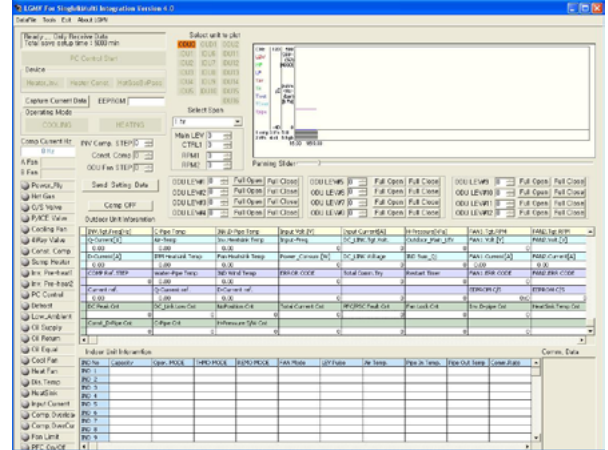

Figure 4: MV Diagnostic Screen - High Version

# PERFORMANCE DATA

[“Cooling Capacity Table” on page 24](#)

[“Heating Capacity Table” on page 25](#)

# PERFORMANCE DATA

## Cooling Capacity

### LAN090HYV/LAU090HYV

Outdoor air temp. (°F DB)	Indoor Air Temp. °F DB/°F WB																				
	64/53			68/57			72/61			77/64			80/67			86/72			90/75		
	TC	SC	PI	TC	SC	PI	TC	SC	PI	TC	SC	PI	TC	SC	PI	TC	SC	PI	TC	SC	PI
14	5.51	5.82	0.24	5.92	5.74	0.24	6.33	5.65	0.25	6.75	5.57	0.26	6.94	5.49	0.27	7.57	5.38	0.28	7.99	5.30	0.29
23	5.92	6.03	0.24	6.36	5.94	0.24	6.80	5.86	0.25	7.24	5.77	0.26	7.45	5.68	0.27	8.13	5.57	0.28	8.57	5.49	0.29
59	7.10	6.48	0.27	7.63	6.38	0.28	8.16	6.29	0.29	8.69	6.20	0.30	8.94	6.10	0.31	9.75	5.98	0.32	10.29	5.89	0.33
70	8.10	7.65	0.40	8.64	7.54	0.41	9.18	7.42	0.43	9.54	7.31	0.44	9.81	7.21	0.45	10.53	7.06	0.47	11.25	6.96	0.49
75	8.00	7.71	0.41	8.54	7.59	0.43	9.08	7.48	0.44	9.45	7.37	0.45	9.72	7.26	0.47	10.40	7.12	0.49	11.16	7.01	0.50
80	7.79	7.77	0.43	8.33	7.65	0.44	8.87	7.54	0.46	9.27	7.43	0.47	9.63	7.32	0.49	10.26	7.17	0.51	10.98	7.06	0.52
85	7.58	7.86	0.46	8.12	7.75	0.48	8.66	7.63	0.49	9.09	7.52	0.51	9.45	7.41	0.52	10.13	7.26	0.54	10.82	7.15	0.56
90	7.37	7.98	0.48	7.91	7.87	0.50	8.45	7.75	0.51	8.91	7.64	0.53	9.27	7.52	0.54	9.99	7.37	0.56	10.60	7.26	0.58
95	7.15	8.02	0.50	7.68	7.91	0.51	8.22	7.79	0.53	8.75	7.67	0.54	9.00	7.56	0.56	9.83	7.41	0.58	10.36	7.30	0.60
100	6.96	8.00	0.50	7.50	7.89	0.52	8.03	7.77	0.54	8.57	7.65	0.55	8.88	7.54	0.57	9.64	7.39	0.59	10.17	7.28	0.61
105	6.77	7.98	0.51	7.31	7.86	0.53	7.84	7.75	0.54	8.38	7.63	0.56	8.77	7.52	0.58	9.45	7.37	0.60	9.99	7.26	0.62
110	6.59	7.96	0.52	7.12	7.84	0.53	7.66	7.73	0.55	8.19	7.61	0.57	8.58	7.50	0.59	9.26	7.35	0.61	9.80	7.24	0.63
115	6.40	7.94	0.52	6.94	7.83	0.54	7.47	7.71	0.56	8.01	7.60	0.57	8.39	7.48	0.59	9.08	7.33	0.61	9.61	7.22	0.63
118	6.21	7.95	0.53	6.75	7.84	0.54	7.20	7.72	0.56	7.74	7.61	0.58	8.10	7.49	0.60	8.78	7.34	0.62	9.27	7.23	0.64
122	5.92	7.98	0.53	6.42	7.86	0.55	6.93	7.74	0.56	7.44	7.63	0.58	7.80	7.52	0.60	8.45	7.37	0.62	8.96	7.26	0.64

### LAN120HYV/LAU120HYV

Outdoor air temp. (°F DB)	Indoor Air Temp. °F DB/°F WB																				
	64/53			68/57			72/61			77/64			80/67			86/72			90/75		
	TC	SC	PI	TC	SC	PI	TC	SC	PI	TC	SC	PI	TC	SC	PI	TC	SC	PI	TC	SC	PI
14	7.35	7.49	0.36	7.90	7.38	0.37	8.45	7.27	0.38	9.00	7.16	0.40	9.25	7.06	0.41	10.10	6.91	0.42	10.65	6.81	0.44
23	7.89	7.76	0.36	8.48	7.64	0.37	9.07	7.53	0.38	9.66	7.42	0.39	9.93	7.31	0.41	10.84	7.16	0.42	11.43	7.05	0.43
59	9.46	8.33	0.41	10.17	8.21	0.43	10.88	8.09	0.44	11.59	7.97	0.45	11.91	7.85	0.47	13.01	7.69	0.49	13.72	7.58	0.50
70	10.80	9.83	0.61	11.52	9.69	0.63	12.24	9.55	0.65	12.72	9.40	0.67	13.08	9.27	0.69	14.04	9.08	0.72	15.00	8.94	0.74
75	10.66	9.91	0.63	11.38	9.76	0.65	12.11	9.62	0.67	12.60	9.48	0.69	12.96	9.34	0.71	13.86	9.15	0.74	14.88	9.01	0.76
80	10.38	9.99	0.65	11.10	9.84	0.67	11.82	9.69	0.70	12.36	9.55	0.72	12.84	9.41	0.74	13.68	9.22	0.77	14.64	9.08	0.79
85	10.11	10.11	0.70	10.83	9.96	0.72	11.54	9.81	0.74	12.12	9.67	0.77	12.60	9.53	0.79	13.50	9.34	0.82	14.42	9.20	0.85
90	9.83	10.26	0.73	10.55	10.11	0.75	11.26	9.96	0.78	11.88	9.82	0.80	12.36	9.67	0.82	13.32	9.48	0.86	14.13	9.34	0.88
95	9.53	10.32	0.75	10.25	10.16	0.78	10.96	10.01	0.80	11.67	9.87	0.82	12.00	9.72	0.85	13.10	9.53	0.88	13.81	9.38	0.91
100	9.28	10.29	0.77	10.00	10.14	0.79	10.71	9.99	0.81	11.42	9.84	0.84	11.84	9.70	0.86	12.85	9.50	0.90	13.56	9.36	0.93
105	9.03	10.26	0.78	9.75	10.11	0.80	10.46	9.96	0.83	11.17	9.82	0.85	11.69	9.67	0.88	12.60	9.48	0.91	13.31	9.33	0.94
110	8.78	10.23	0.79	9.50	10.08	0.81	10.21	9.93	0.84	10.92	9.79	0.86	11.44	9.64	0.89	12.35	9.45	0.92	13.07	9.31	0.95
115	8.53	10.21	0.79	9.25	10.06	0.82	9.96	9.91	0.84	10.67	9.77	0.87	11.19	9.62	0.90	12.10	9.43	0.93	12.82	9.29	0.96
118	8.28	10.23	0.80	9.00	10.08	0.83	9.60	9.93	0.85	10.32	9.78	0.88	10.80	9.64	0.91	11.70	9.44	0.94	12.36	9.30	0.97
122	7.89	10.26	0.81	8.56	10.11	0.83	9.24	9.96	0.86	9.91	9.81	0.88	10.40	9.66	0.91	11.27	9.47	0.95	11.94	9.33	0.97

DB = Dry Bulb Temperature (°F)  
 WB = Wet Bulb Temperature (°F)  
 TC = Total Capacity (kBtu/h).  
 SC = Sensible Capacity (kBtu/h)  
 PI = Power Input (kW) (includes compressor, indoor fan motor and outdoor fan motor).

#### NOTES

- All capacities are net, evaporator fan motor heat is deducted.
- Grey shading Indicates reference data. When operating at this temperature, these values can be different by discontinuous operation.
- Direct interpolation is permissible. Do not extrapolate
- Capacities are based on the following conditions:
  - Interconnecting Piping Length 24.6 ft
  - Level Difference of Zero.
  - Indoor Air Temperature :80°F (26.7°C) DB / 67°F (19.4°C) WB
  - Outdoor Air Temperature :95°F (35.0°C) DB / 75°F (23.9°C) WB



# PERFORMANCE DATA

## Heating Capacity

### LAN090HYV/LAU090HYV

Outdoor Air Temperature (°F DB)   (°F WB)		Indoor Air Temp. °F DB/°F WB													
		60		64		68		70		72		75		86	
TC	PI	TC	PI	TC	PI	TC	PI	TC	PI	TC	PI	TC	PI	TC	PI
-12	-13	5.08	0.48	4.93	0.47	4.88	0.47	4.83	0.47	4.79	0.47	4.69	0.46	4.58	0.46
-3	-4	5.90	0.55	5.72	0.55	5.67	0.55	5.61	0.54	5.57	0.54	5.45	0.54	5.32	0.54
0	-1	6.43	0.61	6.23	0.60	6.17	0.60	6.11	0.60	6.06	0.60	5.94	0.59	5.80	0.59
6	5	6.80	0.64	6.59	0.63	6.53	0.63	6.46	0.62	6.41	0.62	6.28	0.62	6.13	0.62
10	9	7.10	0.66	6.88	0.65	6.81	0.65	6.75	0.64	6.69	0.64	6.56	0.64	6.40	0.64
16	14	7.32	0.66	7.10	0.66	7.03	0.66	6.96	0.65	6.90	0.65	6.77	0.64	6.61	0.64
19	17	7.47	0.68	7.24	0.68	7.17	0.68	7.10	0.67	7.05	0.67	6.90	0.66	6.74	0.66
24	23	8.10	0.69	7.86	0.68	7.78	0.68	7.70	0.67	7.64	0.67	7.49	0.67	7.31	0.67
32	30	9.52	0.70	9.23	0.69	9.14	0.69	9.05	0.69	8.98	0.69	8.80	0.68	8.59	0.68
41	38	10.79	0.71	10.46	0.70	10.35	0.70	10.25	0.69	10.17	0.69	9.97	0.69	9.73	0.69
43	40	11.10	0.71	10.76	0.70	10.66	0.70	10.55	0.70	10.47	0.70	10.26	0.69	10.02	0.69
47	43	11.57	0.71	11.22	0.71	11.11	0.71	11.00	0.70	10.92	0.70	10.70	0.69	10.44	0.69
53	50	11.69	0.72	11.34	0.71	11.22	0.71	11.11	0.71	11.03	0.71	10.80	0.70	10.55	0.70
59	55	11.96	0.73	11.59	0.72	11.48	0.72	11.36	0.71	11.28	0.71	11.05	0.71	10.79	0.71
64	60	12.21	0.74	11.84	0.74	11.72	0.74	11.61	0.73	11.52	0.73	11.29	0.72	11.02	0.72
70	66	12.44	0.75	12.07	0.75	11.94	0.75	11.83	0.74	11.73	0.74	11.50	0.73	11.23	0.73
75	71	12.62	0.76	12.23	0.76	12.11	0.76	11.99	0.75	11.90	0.75	11.66	0.74	11.38	0.74
78	75	12.73	0.77	12.35	0.76	12.22	0.76	12.10	0.76	12.01	0.76	11.77	0.75	11.49	0.75

### LAN120HYV/LAU120HYV

Outdoor Air Temperature (°F DB)   (°F WB)		Indoor Air Temp. °F DB/°F WB													
		60		64		68		70		72		75		86	
TC	PI	TC	PI	TC	PI	TC	PI	TC	PI	TC	PI	TC	PI	TC	PI
-12	-13	6.01	0.59	5.83	0.58	5.77	0.58	5.71	0.57	5.67	0.57	5.55	0.57	5.42	0.57
-3	-4	6.98	0.68	6.77	0.67	6.70	0.67	6.64	0.66	6.59	0.66	6.45	0.66	6.30	0.66
0	-1	7.60	0.74	7.37	0.74	7.30	0.74	7.22	0.73	7.17	0.73	7.02	0.72	6.86	0.72
6	5	8.04	0.78	7.80	0.77	7.72	0.77	7.64	0.76	7.59	0.76	7.43	0.75	7.26	0.75
10	9	8.40	0.80	8.14	0.80	8.06	0.80	7.98	0.79	7.92	0.79	7.76	0.78	7.58	0.78
16	14	8.66	0.81	8.40	0.80	8.31	0.80	8.23	0.80	8.17	0.80	8.01	0.79	7.81	0.79
19	17	8.84	0.84	8.57	0.83	8.48	0.83	8.40	0.82	8.34	0.82	8.17	0.81	7.97	0.81
24	23	9.68	0.84	9.39	0.83	9.29	0.83	9.20	0.83	9.13	0.83	8.95	0.82	8.73	0.82
32	30	11.57	0.86	11.22	0.85	11.11	0.85	11.00	0.84	10.92	0.84	10.70	0.83	10.44	0.83
41	38	13.26	0.87	12.86	0.86	12.73	0.86	12.60	0.85	12.50	0.85	12.25	0.84	11.96	0.84
43	40	13.68	0.87	13.26	0.86	13.13	0.86	13.00	0.86	12.90	0.86	12.64	0.85	12.34	0.85
47	43	14.31	0.88	13.88	0.87	13.74	0.87	13.60	0.86	13.50	0.86	13.23	0.85	12.91	0.85
53	50	14.45	0.89	14.02	0.88	13.87	0.88	13.74	0.87	13.63	0.87	13.36	0.86	13.04	0.86
59	55	14.78	0.89	14.33	0.89	14.19	0.89	14.05	0.88	13.94	0.88	13.66	0.87	13.34	0.87
64	60	15.10	0.91	14.64	0.90	14.49	0.90	14.35	0.89	14.24	0.89	13.95	0.89	13.62	0.89
70	66	15.38	0.93	14.92	0.92	14.77	0.92	14.62	0.91	14.51	0.91	14.22	0.90	13.88	0.90
75	71	15.60	0.94	15.13	0.93	14.97	0.93	14.82	0.92	14.71	0.92	14.42	0.91	14.07	0.91
78	75	15.74	0.95	15.26	0.94	15.11	0.94	14.96	0.93	14.85	0.93	14.55	0.92	14.20	0.92

DB = Dry Bulb Temperature (°F)

WB = Wet Bulb Temperature (°F)

TC = Total Capacity (kBtu/h).

PI = Power Input (kW) (includes compressor, indoor fan motor and outdoor fan motor).

1. All capacities are net, evaporator fan motor heat is deducted.

2. Direct interpolation is permissible. Do not extrapolate

3. Capacities are based on the following conditions:

- Interconnecting Piping Length 24.6 ft
- Level Difference of Zero.
- Indoor Air Temperature  
: 70°F(21.1°C) DB / 60°F(15.6°C) WB
- Outdoor Air Temperature  
: 47°F(8.3°C) DB / 43°F(6.1°C) WB



# APPLICATION GUIDELINES

**“Equipment Selection Procedure” on page 28**

**“Building Ventilation Design Guide” on page 29**

**“Placement Considerations” on page 31**

# EQUIPMENT SELECTION PROCEDURE

## Cooling / Heating Correction Factors

For the Art Cool Premier system, calculate the equivalent length of the liquid line from the outdoor unit to the indoor unit. Also, determine the elevation difference of the indoor unit above or below the outdoor unit. Find corresponding cooling or heating capacity correction factors as shown in Figure 5 and Figure 6. Multiply the correction factors by the cooling or heating capacity obtained from the capacity table using design conditions. The resultant is the NET cooling or heating capacity.

### Capacity Coefficient Factors

Figure 5: Cooling Capacity Coefficient Factor

Cooling

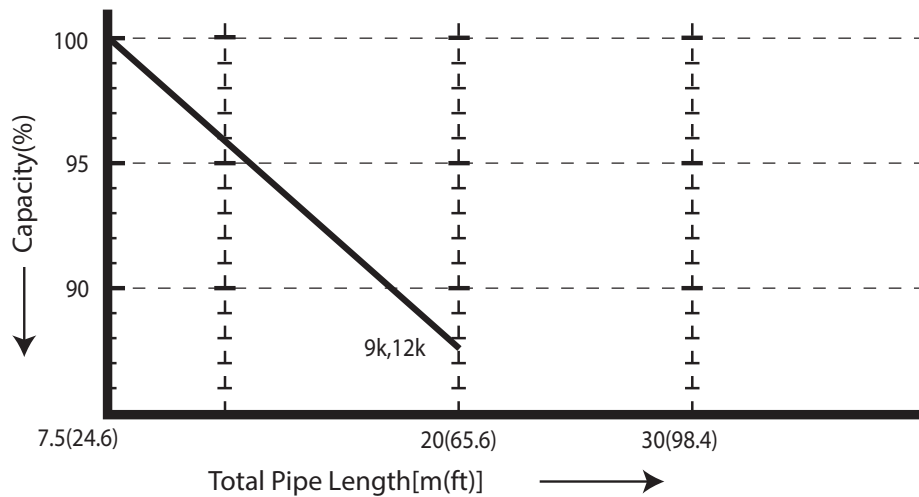
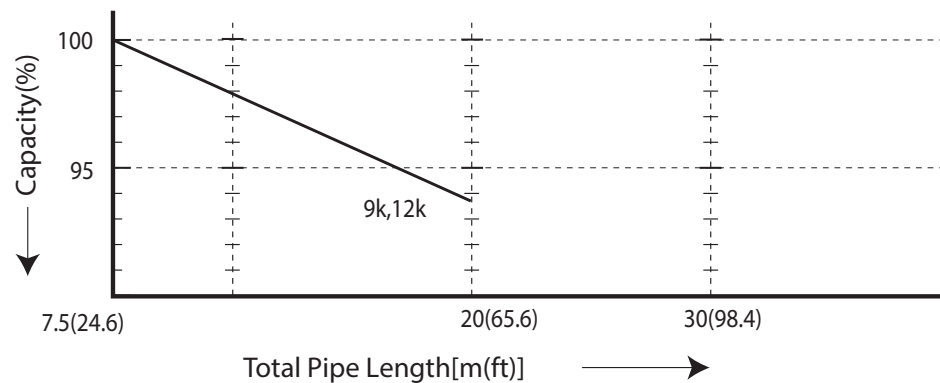

Figure 6: Heating Capacity Coefficient Factor

Heating



## Equivalent Piping Length for Piping Components

Table 7: Equivalent Piping Length for Elbows

Component	Size (Inches)													
	1/4	3/8	1/2	5/8	3/4	7/8	1	1-1/8	1-1/4	1-3/8	1-1/2	1-5/8	1-3/4	2-1/8
Elbow (ft.)	0.5	0.6	0.7	0.8	1.2	1.3	1.5	1.6	1.8	2.0	2.1	2.3	2.5	2.8

# BUILDING VENTILATION DESIGN GUIDE

## Building Ventilation Design Guide

ASHRAE 62.1 and local codes specify the minimum volume of outdoor air that must be provided to an occupied space. Outdoor air is required to minimize adverse health effects, and it provides acceptable indoor air quality for building occupants. The three methods of accomplishing this with LG Single Zone Art Cool Premier systems are summarized here.

### Note:

#### Disclaimer

Although we believe that these building ventilation methods have been portrayed accurately, none of the methods have been tested, verified, or evaluated by LG Electronics, U.S.A., Inc., In all cases, the designer, installer, and contractor should understand if the suggested method is used, it is used at their own risk. LG Electronics U.S.A., Inc., takes no responsibility and offers no warranty, expressed or implied, of merchantability or fitness of purpose if this method fails to perform as stated or intended.

- For a complete copy of Standard 62.1-2010, refer to the American Standard of Heating and Air Conditioning Engineers (ASHRAE) website at [www.ashrae.org](http://www.ashrae.org).
- For more information on how to properly size a ventilation air pretreatment system, refer to the article, "Selecting DOAS Equipment with Reserve Capacity" by John Murphy, published in the ASHRAE Journal, April 2010.

## Method 1: Decoupled Dedicated Outdoor Air System (DDOAS)

Provide a separate, dedicated outdoor-air system designed to filter, condition, and dehumidify ventilation air and deliver it directly to the conditioned space through a separate register or grille. This approach requires a separate independent ventilation duct system not associated with the Single Zone Art Cool Premier system.

### Note:

LG recommends using the DDOAS method in all installations.

#### Advantages

- Does not add additional heating or cooling loads to indoor units.
- May be used with all single zone systems.
- If the outdoor air unit fails, the resulting untreated air will be readily noticed by the occupants.
- The outdoor air unit may supply "neutral" air to the occupant space even when the Single Zone Art Cool Premier indoor unit fan changes speed or cycles on and off. DDOAS controls do not have to be interlocked with the Single Zone Art Cool Premier system.
- In lieu of installing localized smaller outside air treatment equipment throughout the building, this method centralizes the ventilation air source making service and filter changes easier and less disruptive for the building occupants.

- Indoor unit operation and performance will not be affected by the condition of outdoor air.
- Third-party demand control ventilation controls are more readily accommodated.

#### Disadvantages

- Ceiling space is required to accommodate ductwork between the centralized outdoor air unit and ceiling diffusers.

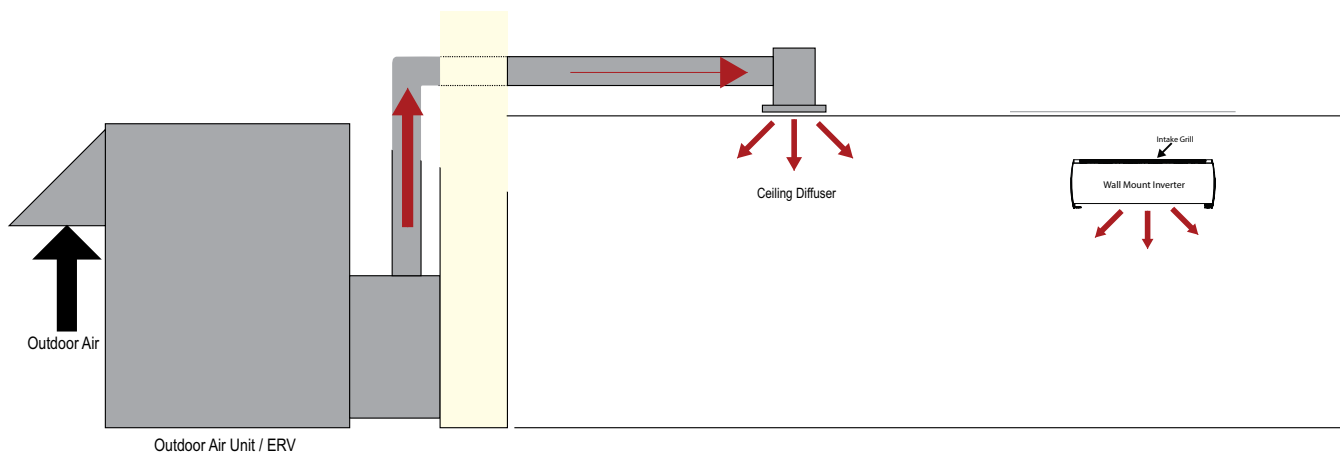

# BUILDING VENTILATION DESIGN GUIDE

## Method 2: Unconditioned Outdoor Air (Non-Ducted, Natural Ventilation)

Natural ventilation devices, such as operable windows or louvers may be used to ventilate the building when local code permits. The open area of a window or the free area of a louver must meet the minimum percentage of the net occupied floor area.

### Advantages

- Occupants control the volume of the ventilation air manually.
- Useful for historic buildings that have no ceiling space available for outdoor air ductwork.
- May be used with all single zone systems..

### Disadvantages

- In some locations, it may be difficult to control humidity levels when windows are open.
- Thermal comfort levels may be substandard when windows are open.
- Indoor units may have to be oversized to account for the added heating and cooling loads when windows are open.
- Provides outdoor air to perimeter spaces only. Additional mechanical ventilation system may be required to satisfy requirements for interior spaces.
- Outdoor air loads may be difficult to calculate since the quantity of outdoor air is not regulated.
- May affect indoor unit proper operation when open.

### Note:

*Methodology illustrations are for examples only and do not depict actual indoor units for the specific outdoor unit pairing. These are generic illustrations to show ventilation design only!*

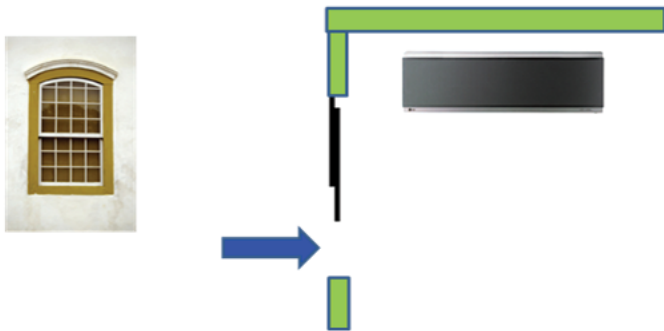

Figure 7: Unconditioned Outdoor Air (Non-Ducted)

## Method 3: Unconditioned Outdoor Air (Non-Ducted, Fan Assisted Ventilation)

When approved by local codes, the fan assisted ventilation method uses exhaust fans to remove air from the building, and outdoor air is drawn into occupied spaces through a wall louver or gravity roof intake hood. Supply fans can also be used to push the outdoor air into the space and building positive pressure will vent the exhaust air through louvers or roof-mounted exhaust hoods. Outdoor air is neither cooled nor heated before entering the building.

### Note:

*This may result in loss of building pressurization control, increasing infiltration loads with adverse effects.*

### Advantages

- Outdoor air may be manually controlled by the occupant or automatic controls may be installed to open/close outdoor air dampers or to turn on/off ventilation fans.
- Useful for large open spaces like warehouses, garages, and workshops.
- Outdoor air volume is a known quantity. Air loads may be easier to calculate since fans will regulate the amount of outdoor air.
- May be used with all single zone systems..

### Disadvantages

- In some locations of the country, it may be difficult to control humidity levels while outdoor air louvers/hoods are opened.
- Thermal comfort levels may be substandard when louvers/hoods are opened.
- Indoor units may have to be oversized to account for the added heating/cooling loads when louvers/hoods are open.
- Hot, cold, and/or humid areas may be present if the outdoor air is not evenly distributed to the different spaces.

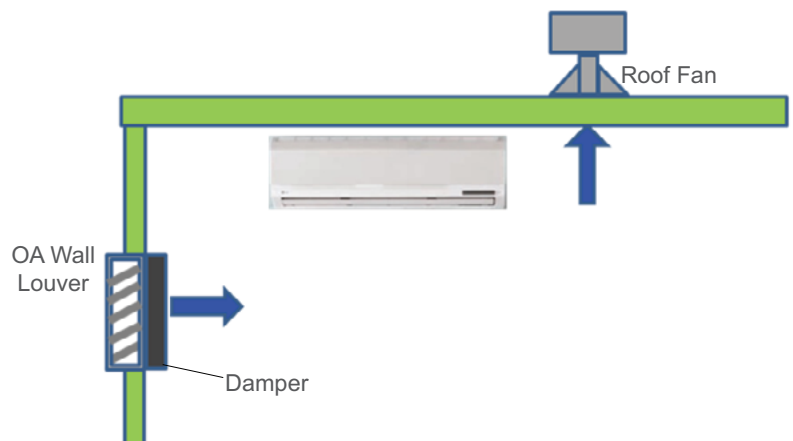

Figure 8: Unconditioned Outdoor Air (Non-Ducted).

# PLACEMENT CONSIDERATIONS

## Single Zone Art Cool Premier

---

---

### Selecting the Best Location

Select a location for installing the outdoor unit that will meet the following conditions:

- Where the unit will not be subjected to direct thermal radiation from other heat sources.
- Where operating sound from the unit will not disturb inhabitants of surrounding buildings.
- Where the unit will not be exposed to direct, strong winds.
- Where there is enough strength to bear the weight of the unit.
- Include space for drainage to ensure condensate flows properly out of the unit when it is in heating mode.
- Include enough space for air flow and for service access.
- To avoid the possibility of fire, do not install the unit in an area where combustible gas may generate, flow, stagnate, or leak.
- Do not install the unit in a location where acidic solution and spray (sulfur) are often used.
- Do not use the unit in environments where oil, steam, or sulfuric gas are present.
- Install a fence to prevent vermin from crawling into the unit or unauthorized individuals from accessing it.

To ensure the outdoor unit operates properly, certain measures are required in locations where there is a possibility of heavy snowfall or severe windchill or cold:

1. Prepare for severe winter wind chills and heavy snowfall, even in areas of the country where these are unusual phenomena.
2. Position the outdoor unit so that its airflow fans are not buried by direct, heavy snowfall. If snow piles up and blocks the airflow, the system may malfunction.
3. Remove any snow that has accumulated 3-15/16 inches or more on the top of the outdoor unit.
4. Place the outdoor unit on a raised platform at least 19-11/16 inches higher than the average annual snowfall for the area. In environments where there is a possibility of heavy snow, the frame height must be more than two (2) times the amount of average annual snowfall, and should not exceed the width of the outdoor unit. If the frame width is wider than the outdoor unit, snow may accumulate.
5. Install a snow protection hood.
6. To prevent snow and heavy rain from entering the outdoor unit, install the suction and discharge ducts facing away from direct winds.

Additionally, the following conditions should be taken into considerations when the unit operates in defrost mode:

- If the outdoor unit is installed in a highly humid environment (near an ocean, lake, etc.), ensure that the site is well-ventilated and has a lot of natural light. (Example: Install on a rooftop.)
- Sidewalks or parking lots near the outdoor unit may accumulate moisture after unit operates in defrost mode that can turn to ice.

The indoor unit may take longer to provide heat, or heating performance will be reduced in winter if the unit is installed:

1. In a narrow, shady location.
2. Near a location that has a lot of ground moisture.
3. In a highly humid environment.
4. In an area in which condensate does not drain properly.

# PLACEMENT CONSIDERATIONS

## Outdoor Installation

### General Mounting

Securely attach the outdoor unit to a condenser pad, base rails, or other mounting platform that is securely anchored to the ground or building structure. Attach the ODU with a bolt and nut onto a concrete or rigid mount (Figure 9). Refer to installation manual and follow the applicable local code for clearance, mounting, anchor, and vibration attenuation requirements.

**Note:**

All referenced materials are to be field-supplied. Images are not to scale.

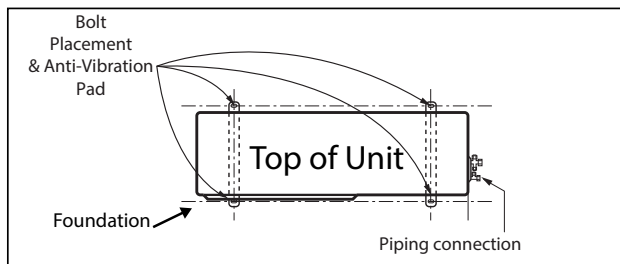
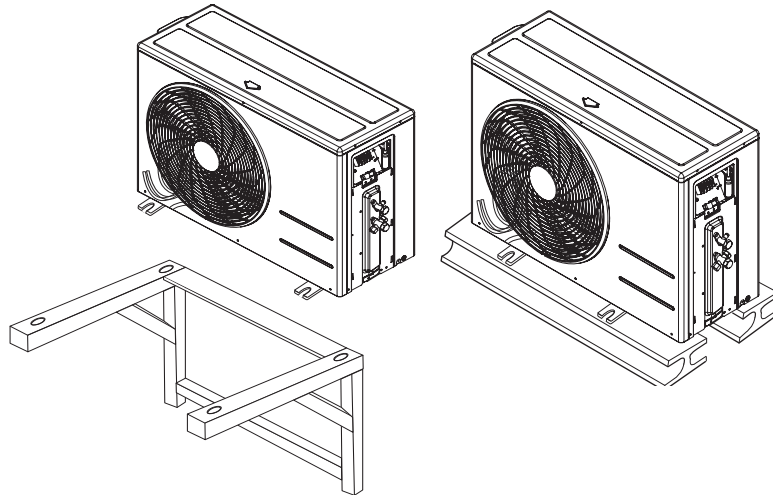

Figure 9: Art Cool Premier Outdoor Unit—Mounting Methods



### Mounting Platform

The underlying structure or foundation must be designed to support the weight of the unit. Avoid placing the unit in a low lying area where water may accumulate. When installing ODU on the wall, or roof top, anchor the mounting base securely using nails or wire with regard to wind and earthquake or vibration.

### Tie-Downs and Wind Restraints

The strength of the Single Zone Art Cool Premier frame is adequate to be used with field-provided wind restraint tie-downs. The overall tie-down configuration must be approved by a local professional engineer. Always refer to local code when designing a wind restraint system.

### Snow and Ice Conditions

In climates that experience snow buildup, place the unit on a raised platform to ensure proper condenser airflow. The raised support platform must be high enough to allow the unit to remain above possible snow drifts. Mount the unit on a field-provided snow stand at a minimum height that is equal to the average annual snowfall, plus 20 inches. Design the mounting base to prevent snow accumulation on the platform in front or back of the unit case. If necessary, provide a field fabricated hood to keep snow and ice and/or drifting snow from accumulating on the coil surfaces. Use inlet and discharge duct or hoods to prevent snow or rain from accumulating on the fan inlet and outlet guards. Best practice prevents snow from accumulating on top of the unit. Consider tie-down requirements in case of high winds or where required by local codes.

**Note:**

When deciding on a location to place the outdoor unit, be sure to choose an area where run-off from defrost will not accumulate and freeze on sidewalks or driveways.

### Ambient Air Conditions

Avoid exposing the outdoor unit to steam, combustible gases, or other corrosive elements. Avoid exposing the unit to discharge from boiler stacks, chimneys, steam relief ports, other air conditioning units, kitchen vents, plumbing vents, and other sources of extreme temperature, gases, or substances that may degrade performance or cause damage to the unit.

When installing multiple outdoor units, avoid placing the units where discharge of one outdoor unit will blow into the inlet side of an adjacent unit.



# PLACEMENT CONSIDERATIONS

## Outdoor Installation

### Single Zone Art Cool Premier Wall Mount Outdoor Unit Clearance

Proper airflow through the outdoor unit coil is critical for proper unit operation. When installing the outdoor unit, consider service, inlet, and outlet, and minimum allowable space requirements as illustrated in the diagrams below. All units are in inches

Figure 10: Art Cool Premier Outdoor Unit Clearance

Figure 11: Art Cool Premier Outdoor Unit Next to Wall - Clearance

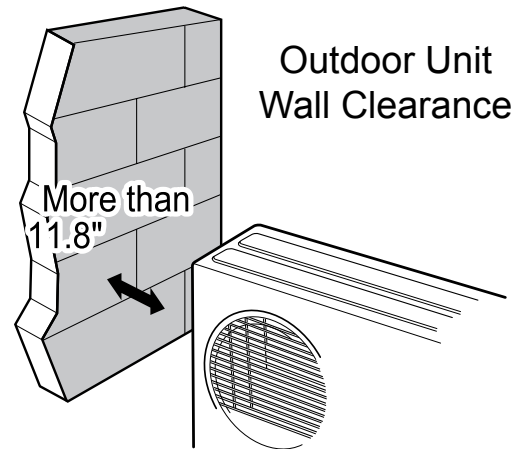
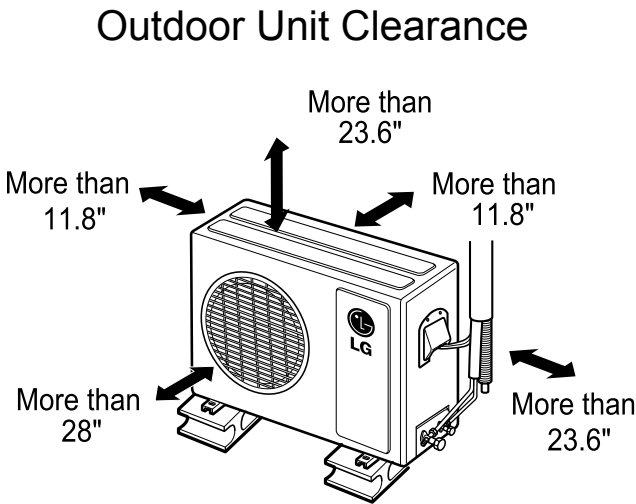

When placing the outdoor unit near a fence, wall or other large obstacle, observe the clearance requirements as shown in Figure 10. This clearance ensures that heat radiation from the condenser is not restricted around the unit. Adhere to all clearance requirements if installing the unit on a roof. Be sure to level the unit and ensure that unit is adequately anchored. Consult local codes regarding rooftop mounting.

Figure 12: Art Cool Premier Outdoor Unit Under Roof/Overhang

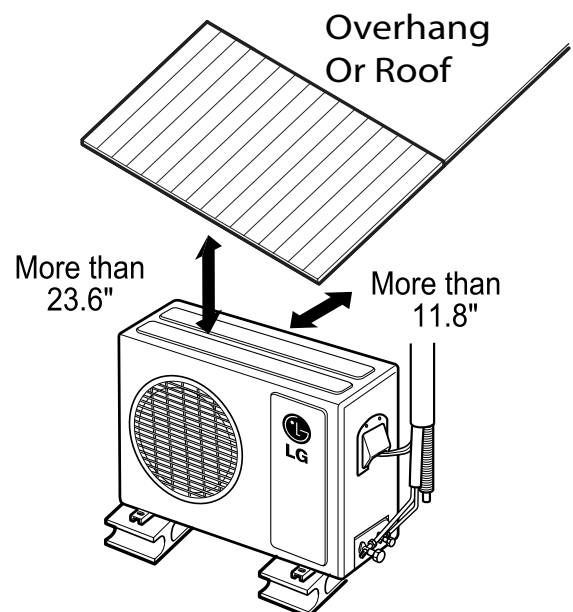

**Note:**

Do not place the unit where animals and/or plants will be in the path of the warm air; or where the warm air and/or noise will disturb neighbors.



# REFRIGERANT PIPING DESIGN & LAYOUT BEST PRACTICES

**"Refrigerant Piping Design" on page 36**

**"Selecting Field-Supplied Copper Tubing" on page 37**

**"Refrigerant Piping System Layout" on page 38**

**"Piping Connection" on page 41**

**"Electrical Connections" on page 43**

**"Mechanical Specifications" on page 44**

**"Acronyms" on page 45**

# REFRIGERANT PIPING DESIGN

## Design Guideline Summary

### Device Connection Limitations

A Single Zone Art Cool Premier Wall Mount system consists of one outdoor unit and one indoor unit.

One of the most critical elements of a Art Cool Premier Wall Mount system is the refrigerant piping. Table 8 below lists pipe length limits that must be followed in the design of a Single Zone Wall Mount refrigerant pipe system:

Table 8: Art Cool Premier Wall Mount Refrigerant Piping System Limitations

Pipe Length (ELF = Equivalent Length of pipe in Feet)	Longest total equivalent piping length	65.6 feet
	Distance between fittings and indoor or outdoor units	≥ 20 inches
Elevation (All Elevation Limitations are Measured in Actual Feet)	If outdoor unit is above indoor unit	32.8 feet
	If outdoor unit is below indoor unit	32.8 feet

### DFS System Layout

Figure 13: Typical DFS System Layout

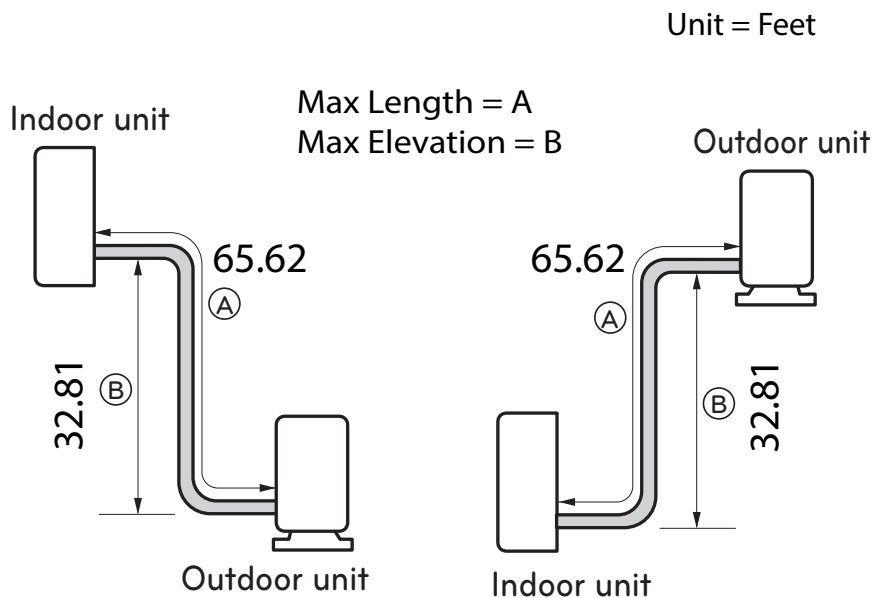

# REFRIGERANT PIPING DESIGN

## Selecting Field-Supplied Copper Tubing

Table 9: Linear Thermal Expansion of Copper Tubing in Inches

Pipe Length <sup>1</sup>	Fluid Temperature °F																			
	35°	40°	45°	50°	55°	60°	65°	70°	75°	80°	85°	90°	95°	100°	105°	110°	115°	120°	125°	130°
10	0.04	0.04	0.05	0.06	0.06	0.07	0.08	0.08	0.09	0.09	0.10	0.10	0.11	0.11	0.11	0.12	0.13	0.14	0.15	0.15
20	0.08	0.08	0.10	0.12	0.13	0.14	0.15	0.16	0.17	0.18	0.19	0.20	0.21	0.22	0.22	0.23	0.26	0.28	0.29	0.30
30	0.12	0.12	0.15	0.18	0.20	0.21	0.23	0.24	0.26	0.27	0.29	0.30	0.32	0.33	0.32	0.35	0.39	0.42	0.44	0.45
40	0.16	0.16	0.20	0.24	0.26	0.28	0.30	0.32	0.34	0.36	0.38	0.40	0.42	0.44	0.43	0.46	0.52	0.56	0.58	0.60
50	0.20	0.20	0.25	0.30	0.33	0.35	0.38	0.40	0.43	0.45	0.48	0.50	0.53	0.55	0.54	0.58	0.65	0.70	0.73	0.75
60	0.24	0.24	0.30	0.36	0.39	0.42	0.45	0.48	0.51	0.54	0.57	0.60	0.63	0.66	0.65	0.69	0.78	0.84	0.87	0.90

<sup>1</sup>Pipe length baseline temperature = 0°F. "Expansion of Carbon, Copper and Stainless Steel Pipe," *The Engineers' Toolbox*, www.engineeringtoolbox.com.

Figure 14: Coiled Expansion Loops and Offsets.

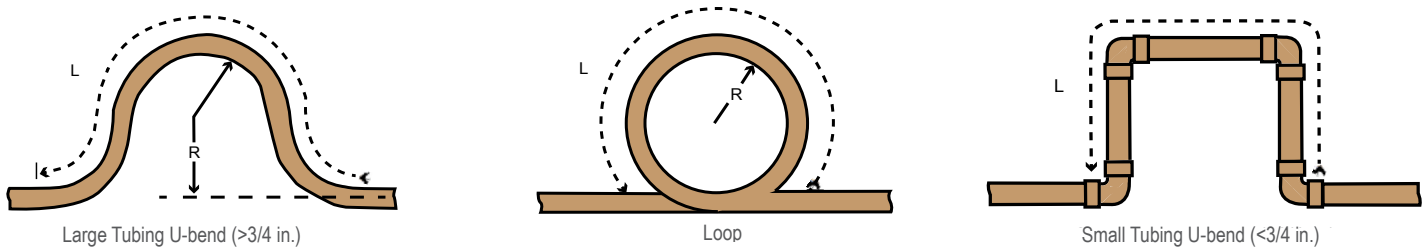

Table 10: Radii of Coiled Expansion Loops and Developed Lengths of Expansion Offsets

Anticipated Linear Expansion (LE) (inches)		Nominal Tube Size (OD) inches	
		1/4	3/8
1/2	R <sup>1</sup>	6	7
	L <sup>2</sup>	38	44
1	R <sup>1</sup>	9	10
	L <sup>2</sup>	54	63
1-1/2	R <sup>1</sup>	11	12
	L <sup>2</sup>	66	77
2	R <sup>1</sup>	12	14
	L <sup>2</sup>	77	89
2-1/2	R <sup>1</sup>	14	16
	L <sup>2</sup>	86	99
3	R <sup>1</sup>	15	17
	L <sup>2</sup>	94	109
3-1/2	R <sup>1</sup>	16	19
	L <sup>2</sup>	102	117
4	R <sup>1</sup>	17	20
	L <sup>2</sup>	109	126

<sup>1</sup>R = Centerline Length of Pipe.  
<sup>2</sup>L = Centerline Minimum Radius (inches).

# INSTALLATION & LAYOUT BEST PRACTICES

## Refrigerant Piping System Layout

### Definitions

**Physical Pipe Length:** Actual length of straight segment(s) of pipe.

**Equivalent Pipe Length:** Actual length of pipe plus equivalent lengths of elbows and valves.

### Layout Procedure

1. Draft a one-line diagram of the proposed piping system connecting outdoor unit to indoor unit. Follow the pipe limitations listed.
2. Calculate the physical length of each pipe segment and note it on the drawing.
3. Calculate the equivalent pipe length of each pipe segment.

### Using Elbows

Field-supplied elbows are allowed as long as they are designed for use with R410A refrigerant. The designer, however, should be cautious with the quantity and size of fit-

tings used, and must account for the additional pressure losses in equivalent pipe length calculation. The equivalent pipe length of each elbow must be added to each pipe segment. See Table 11 for equivalent lengths.

Table 11: Equivalent Piping Length for Piping Components

Component	Size (Inches)				
	1/4	3/8	1/2	5/8	3/4
Elbow (ft.)	0.5	0.6	0.7	0.8	1.2

### Field-Provided Isolation Ball Valves

It is acceptable to install field-supplied ball valves with Schrader ports at the indoor unit. Full-port isolation ball valves with Schrader ports (positioned between valve and the indoor unit) rated for use with R410A refrigerant should be used on both the liquid and vapor lines.

If valves are not installed and the indoor unit needs to be removed or repaired, the entire system must be shut down and evacuated.

Position valves with a minimum distance of three (3) to six (6) inches of pipe on either side of the valve. Valves shall be easily accessible for service. If necessary, install drywall access doors or removable ceiling panels, and position the valves to face the access door or ceiling panel opening. Mount valves with adequate space between them to allow for placement of adequate pipe insulation around the valves. Recommended best practice is to clearly label and document locations of all service valves. The equivalent pipe length of each ball valve must be added to each pipe segment.

### Obstacles

When an obstacle, such as an I-beam or concrete T, is in the path of the planned refrigerant pipe run, it is best practice to route the pipe over the obstacle. If adequate space is not available to route the insulated pipe over the obstacle, then route the pipe under the obstacle. In either case, it is imperative the horizontal section of pipe above or below the obstacle be a minimum of three (3) times greater than the longest vertical rise (or fall) distance (Figure 15).

Figure 15: Installing Piping Above and Below an Obstacle

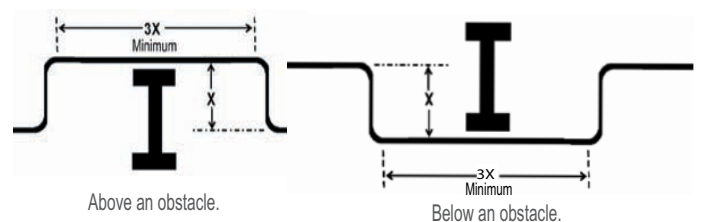

# INSTALLATION & LAYOUT BEST PRACTICES

## Refrigerant Piping System Layout

### In-line Refrigeration Components

Components such as oil traps, solenoid valves, filter-dryers, sight glasses, tee fittings, and other after-market accessories are not permitted on the refrigerant piping system between the outdoor unit and the indoor unit. Art Cool Premier Wall Mount air-source systems are provided with redundant systems that assure oil is properly returned to the compressor. Sight-glasses and solenoid valves may cause vapor to form in the liquid stream. Over time, dryers may deteriorate and introduce debris into the system. The designer and installer should verify the refrigerant piping system is free of traps, sagging pipes, sight glasses, filter dryers, etc.

### No Pipe Size Substitutions

Using a different size is prohibited and may result in a system malfunction or failure to work at all.

### Pipe Supports

A properly installed pipe system should be adequately supported to avoid pipe sagging. Sagging pipes become oil traps that lead to equipment malfunction.

Pipe supports should never touch the pipe wall; supports shall be installed outside (around) the primary pipe insulation jacket (see Figure 16). Insulate the pipe first because pipe supports shall be installed outside (around) the primary pipe insulation jacket. Clevis hangers should be used with shields between the hangers and insulation. Field provided pipe supports should be designed to meet local codes. If allowed by code, use fiber straps or split-ring hangers suspended from the ceiling on all-thread rods (fiber straps or split ring hangers can be used as long as they do not compress the pipe insulation). Place a second layer of insulation over the pipe insulation jacket to prevent chafing and compression of the primary insulation within the confines of the support pipe clamp.

A properly installed pipe system will have sufficient supports to avoid pipes from sagging during the life of the system. As necessary, place supports closer for segments where potential sagging could occur. Maximum spacing of pipe supports shall meet local codes. If local codes do not specify pipe support spacing, pipe shall be supported:

- Maximum of five feet (5') on center for straight segments of pipe up to 3/4" outside diameter size.

Whenever the pipe changes direction, place a hanger within twelve (12) inches on one side and within twelve to nineteen (12 to 19) inches of the bend on the other side as shown in Figure 17.

Figure 16: Pipe Hanger Details

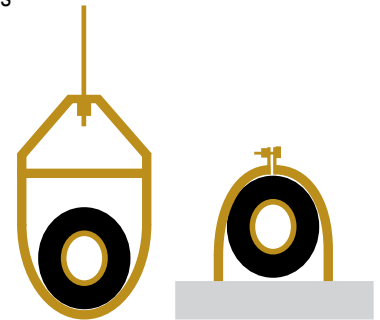

Figure 17: Typical Pipe Support Location—Change in Pipe Direction

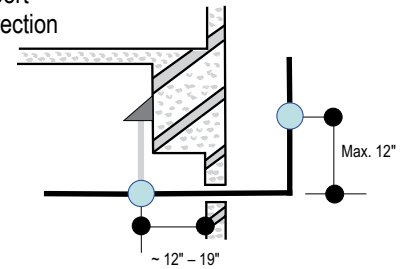
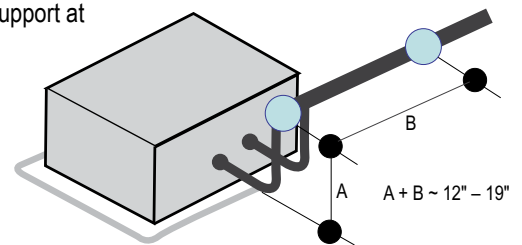

Figure 18: Pipe Support at Indoor Unit



# INSTALLATION & LAYOUT BEST PRACTICES

## Refrigerant Piping System Layout

### Pipe Sleeves at Penetrations

LG requires that all pipe penetrations through walls, floors, and pipes buried underground be properly insulated and routed through an appropriate wall sleeve of sufficient size to prevent compression of refrigerant pipe insulation and free movement of the pipe within the sleeve. Underground refrigerant pipe shall be routed inside a protective sleeve to prevent insulation deterioration.

Figure 19: Pipe Sleeve Options

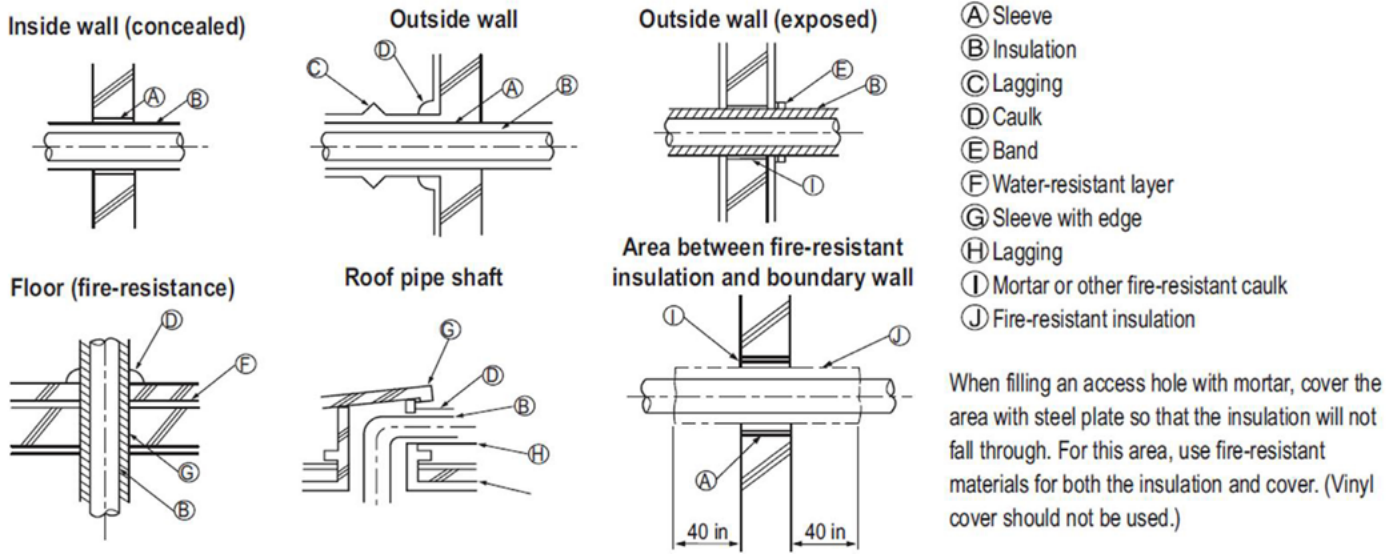

**Note:**

Diameter of penetrations shall be determined by pipe diameter plus the thickness of the insulation.

### Underground Refrigerant Piping

Refrigerant pipe installed underground should be routed inside a vapor tight protective sleeve to prevent insulation deterioration and water infiltration. Refrigerant pipe installed inside underground casing must be continuous without any joints. Underground refrigerant pipe must be located at a level **below the frost line**.

Figure 20: Typical Arrangement of Refrigerant Pipe and Cable(s) in a Utility Conduit

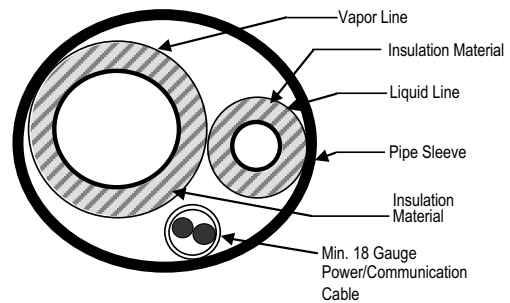

Table 12: Utility Conduit Sizes (Inches)

Liquid Pipe <sup>1</sup>	Vapor Pipe <sup>1</sup>		
	3/8 (1-1/8 <sup>2,3</sup> )	1/2 (2.0 <sup>2,4</sup> )	5/8 (2-1/8 <sup>2,4</sup> )
1/4 (1.0) <sup>4</sup>	4	4	4
3/8 (1-1/8) <sup>4</sup>	4	4	4

<sup>1</sup>OD pipe diameter in inches; Values in parenthesis ( ) indicate OD of pipe with insulation jacket.  
<sup>2</sup>Diameter of pipe with insulation. Thickness of pipe insulation is typical. Actual required thickness may vary based on surrounding ambient conditions and should be calculated and specified by the design engineer.  
<sup>3</sup>Insulation thickness (value in parenthesis) = 3/8 inch.  
<sup>4</sup>Insulation thickness (value in parenthesis) = 3/4 inch.

Table 13: Heat Pump Unit Refrigerant Pipe Connections (All Brazed Type)

Model	Liquid Conn. (inches)	Vapor Conn. (inches)
LAU090HYV, LAU120HYV	1/4	3/8



# INSTALLATION & LAYOUT BEST PRACTICES

## Piping Connection

### Single Zone Art Cool Premier Connections

#### Pipe Connection for a Single Zone System

1. Remove the connection cover from the unit by loosening the fastening screw (Figure 21).
2. Align the center of the refrigerant pipe and corresponding connection as shown in Figure 22 and tighten the flare nut by hand.
3. Tighten the flare nut with a torque wrench until the wrench clicks. Follow the guidelines as outline in Table 14 for the amount of torque to use.

**Note:**

When tightening the flare nut with torque wrench, ensure the direction for tightening follows the arrow on the wrench.

Figure 21: Heat Pump Outdoor Unit Removal of Connection Cover

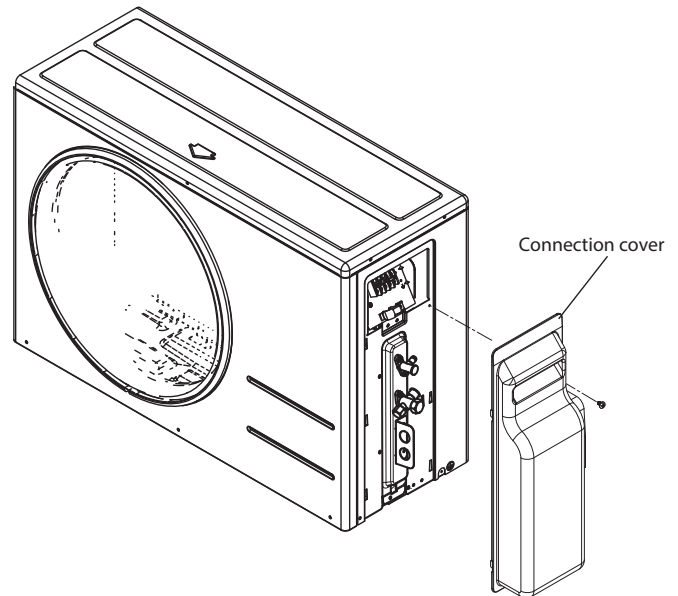

Figure 22: Heat Pump Outdoor Unit Piping Connection

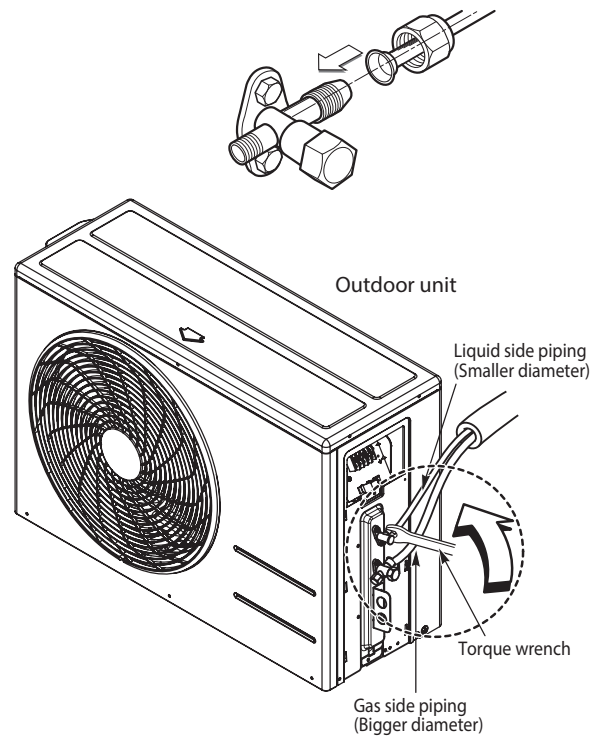

Table 14: Torque Wrench Tightening

Outside Diameter (Inches)	Torque (Lbs.-ft)
1/4	13-18
3/8	24.6-30.4
1/2	39.8-47.7
5/8	45.6-59.3
3/4	71.6-87.5

# INSTALLATION & LAYOUT BEST PRACTICES

## Refrigerant Piping System Layout

### Installation of Refrigerant Piping / Brazing Practices

**Note:**

Keep the piping system free of contaminants and debris such as copper burrs, slag, or carbon dust during installation.

All joints are brazed in the field. Art Cool Premier refrigeration system components contain very small capillary tubes, small orifices, electronic expansion valves, oil separators, and heat exchangers that can easily become blocked. Proper system operation depends on the installer using best practices and utmost care while assembling the piping system (see Figure 23).

- While brazing, use a dry nitrogen purge operating at a minimum pressure of three (3) psig and maintain a steady flow.
- Blow clean all pipe sections with dry nitrogen prior to assembly.
- Use a tubing cutter, do not use a saw to cut pipe. De-burr and clean all cuts before assembly.
- Store pipe stock in a dry place. Keep pipe capped and clean.
- Use adapters to assemble different sizes of pipe.
- Do not use flux, soft solder, or anti-oxidant agents.
- Use a 15% silver phosphorous copper brazing alloy to avoid overheating and produce good flow.
- Protect isolation valves, electronic expansion valves, and other heat-sensitive control components from excessive heat with a wet rag or a heat barrier spray product

Figure 23: Refrigerant Pipe Brazing

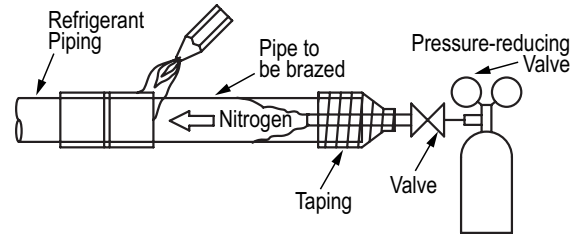

### Refrigerant Piping System Insulation

All refrigerant piping, field-provided isolation ball valves, service valves, and elbows shall be completely insulated using closed cell pipe insulation. The liquid and vapor lines must be insulated separately.

To prevent heat loss/heat gain through the refrigerant piping, all refrigerant piping including liquid lines, and vapor lines shall be insulated separately. Insulation shall be a minimum 1/2" thick, and thickness needs to be increased based on ambient conditions and local codes.

All insulation joints are to be glued with no air gaps. Insulation material must fit snugly against the refrigeration pipe with no air space between it and the pipe. Insulation passing through pipe hangers, inside conduit, and/or sleeves must not be compressed. Protect insulation inside hangers and supports with a second layer. All pipe insulation exposed to the sun and outdoor elements shall be properly protected with PVC, aluminum vapor barrier, or alternatively placed in a weather-resistant enclosure such as a pipe rack with a top cover; and meet local codes.

The design engineer performs calculations to determine if the factory-supplied insulation jackets are sufficient to meet local codes and avoid sweating. Add additional insulation if necessary. Mark all pipes at the point where the insulation jacket ends. Remove the jacket. Install field provided insulation on the run-out and main trunk pipes first. Peel the adhesive glue protector slip from the insulation jacket and install the clam-shell jacket over the fitting.

# ELECTRICAL CONNECTIONS

## Outdoor Unit Electrical Connection

### Procedure

1. Remove the conduit cover from the unit by loosening the fastening screws (Figure 24).
2. Take off the caps on the conduit panel.
3. Connect both the power supply and low voltage lines to the corresponding terminals on the terminal block.
4. Be sure to ground the unit by following local codes.
5. Allow for enough length (add several inches) for each wiring.
6. Secure the cable with the cord clamp.
7. Secure conduit tubes with lock nuts.
8. Refix the control cover to the original position with the fastening screw.

Figure 24: Electrical Connection to Outdoor Unit

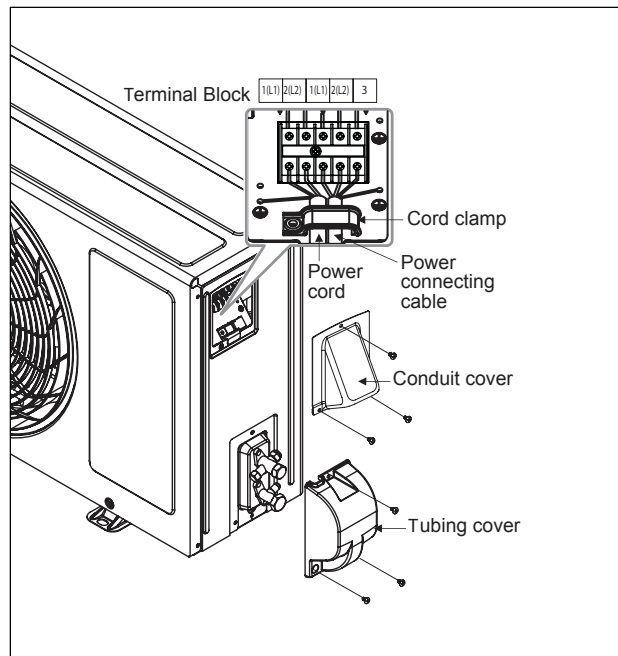

### Note:

Always use a circuit breaker or time delay fuse when connecting electrical wiring to the unit (Figure 25).

### ⚠ WARNING

- Comply with local codes while running wire from the indoor unit to the outdoor unit.
- Be sure to connect wire firmly.
- Separately wire the high and low voltage lines.
- Use heat-proof electrical wiring capable of withstanding temperatures up to 167°F.
- Use outdoor and waterproof connection cable rated up to 300V for the connection between indoor and outdoor unit.
- Do not allow wire to touch refrigerant tubing, the compressor or any moving parts.

Figure 25: Circuit Breaker/Time Delay Fuse Connection

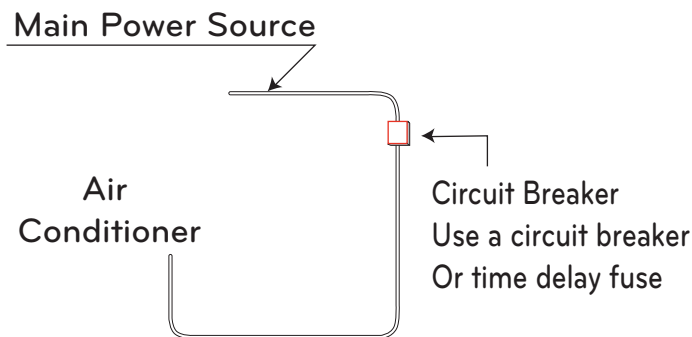

# MECHANICAL SPECIFICATIONS

## Single Zone Art Cool Premier

### General

LG Single Zone Art Cool Premier system comprises of a single outdoor unit connected to a single indoor unit with a single refrigerant circuit.

An LG Single Zone Art Cool Premier system is a DFS system that can operate in either cooling or heating mode. The system shall be capable of changing mode within a maximum time of three (3) minutes to ensure indoor temperature can be properly maintained.

LG components are manufactured in a facility registered to ISO 9001 and ISO 14001, which is a set of standards applying to environmental protection set by the International Organization for Standardization (ISO). The units are listed by Intertek Electrical Testing Laboratories (ETL) and bear the ETL label. Wiring in these units are in accordance with the National Electrical Code (NEC).

### Temperature Ranges

#### Outdoor Unit

Operating ranges for Outdoor units of 14°F to 118°F for cooling; -13°F to 75°F for heating

Operating ranges for Indoor Units of 64°F to 90°F for cooling; 60°F to 86°F for heating

### Casing / Frame

Outdoor unit is constructed with pre-coated metal (PCM).

Indoor unit is constructed of heavy duty Acrylonitrile Butadiene Styrene (ABS) and High Impact Polystyrene (HIPS) plastic."

### Refrigerant System

The refrigeration system consists of a single refrigeration circuit and uses R410A refrigerant. The outdoor unit is provided with factory

installed components, including a refrigerant strainer, check valves, oil separator, accumulator, four-way reversing valve, electronic controlled expansion valve (EEV), high and low side charging ports, service valves, and interconnecting piping.

### Refrigeration Oil Control

Heat Pump outdoor units have a centrifugal oil separator and controls to ensure sufficient oil supply is maintained, and that oil does not travel with the refrigerant.

### Compressors

The outdoor unit is equipped with one hermetic digitally controlled inverter driven twin rotary compressor to modulate capacity (variable from 10 to 115Hz, modulate in 1 Hz increments). Over-current protection and vibration isolation are integrated with the compressor.

### Outdoor Unit Coil

Heat Pump outdoor unit coils are of a nonferrous construction with louvered fins on copper tubing, and are protected with an integral coil guard. Coil fins have a factory applied corrosion resistant GoldFin™ material with hydrophilic coating.

### Fans and Motors

The outdoor unit includes one direct drive, variable speed propeller type fan.

The Brushless Digitally Controlled (BLDC) fan motor shall have inherent protection, permanently lubricated bearings, and variable speed with a maximum speed up to 950 rpm. Raised guards are provided to limit contact with moving parts.

The outdoor unit has horizontal discharge airflow.

### Electrical

The unit is available in 208-230V 60 Hz, 1-phase power supply. The unit is capable of operating within voltage limits of  $\pm 10\%$  rated voltage, and include overcurrent protection.

### Controls

The unit is factory wired with necessary electrical control components, integral microprocessors, printed circuit boards, thermistors, sensors, terminal blocks, and lugs for power wiring.

Microprocessor-based algorithms provide component protection, soft-start capability, refrigeration system pressure, temperature, defrost, and ambient control.

Table 15: Table of Acronyms

ABS	Acrylonitrile Butadiene Styrene	kW	Kilo Watts
AC	Air Conditioner	LED	Light Emitting Diode
ACP	Advanced Control Platform	LEED	Leadership in Energy and Environmental Design
ASHRAE	American Society of Heating, Refrigeration, and Air Conditioning	MBh	Thousands BTUs per hour
AWG	American Wire Gauge	MCA	Maximum Circuit Ampacity
BLDC	Brushless Digitally Controlled	MOP	Maximum Overcurrent Protection
Btu/h	British Thermal Units per hour	MSC	Maximum Starting Current
BUS	Binary Unit System	NC	Noice Criterion (regarding Sound Pressure Levels)
CFM	Cubic Feet per Minute		New Construction (LEED Related)
DB	Dry Bulb		Normally Closed
dB(A)	Decibels with "A" frequency weighting	NEC	National Electrical Code
DDOAS	Decoupled Dedicated Outdoor Air System	NO	Number
DI	Digital Input	ODU	Outdoor Unit
DFS	Duct Free Split	PCB	Printed Circuit Board
DO	Digital Output	PCM	Pre-Coated Metal
DPST	Double-Pole Single-Throw (switch)	PDI	Power Distribution Indicator
EEV	Electronic Expansion Valve	PI	Power Input
ELF	Equivalent Length in Feet	PR	Prerequisite (LEED Related)
ETL	Electronic Testing Laboratories	PVC	Polyvinyl Chloride
H/M/L	High/Medium/Low	SW or S/W	Switch
HIPS	High Impact Polystyrene	USB	Universal Serial BUS
HVAC	Heating, Ventilation and Air Conditioning	VAC	Voltage Alternating Current
ID	Innovations in Design (LEED Related)	VRF	Variable Refrigerant Flow
IDU	Indoor Unit	WB	Wet Bulb
ISO	International Organization for Standardization		

*Inverter*

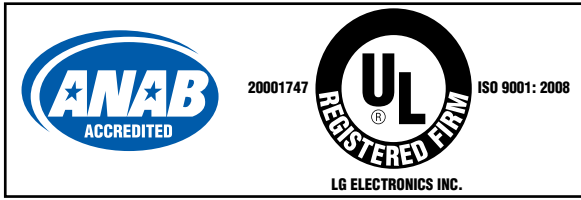

LG Electronics  
Commercial Air Conditioning Division  
11405 Old Roswell Road  
Alpharetta, Georgia 30009  
[www.lg-vrf.com](http://www.lg-vrf.com)

LG Electronics Commercial Products Support  
1-888-865-3026 USA  
Follow the prompts for commercial A/C products.

DFS-EM-AG-001-US\_014A07  
Supersedes: DFS-EM-AG-001-US\_013M12